



## Heating Systems

# OWNER'S MANUAL

CE-340 Multi-Oil Boiler  
With CE-4 Burner

CRN 8949.7980YTN

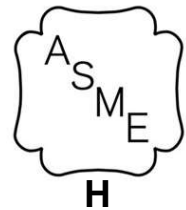
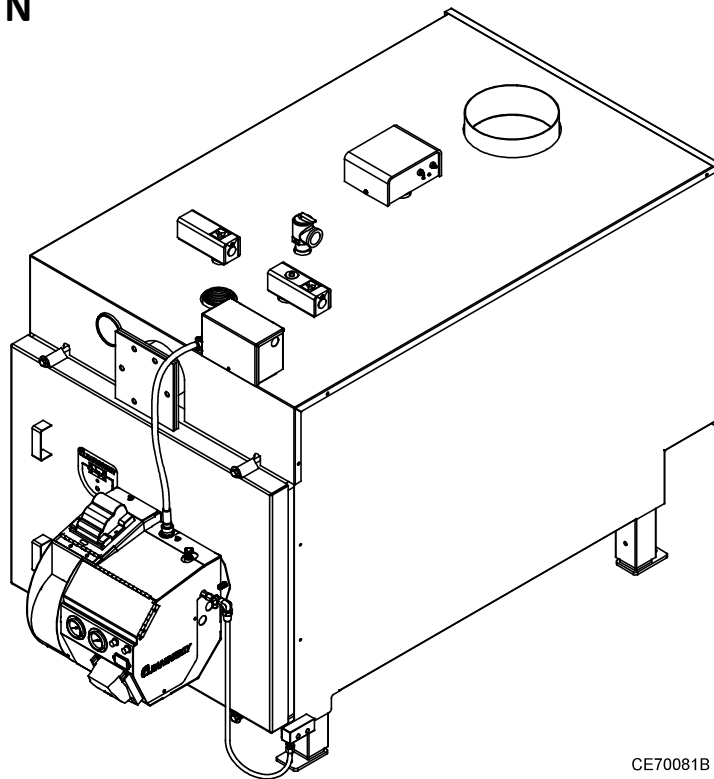

CE70081B

Clean Energy Heating Systems, LLC  
PO Box 1341, 479 Maple Street, Honey Brook, PA 19344  
[www.CleanEnergyHeatingSystems.com](http://www.CleanEnergyHeatingSystems.com)  
(888) 519-2347



**WARNING:** For your safety - DO NOT store gasoline or other flammable vapors and liquids in the vicinity of this or any appliance.

Underwriters Laboratories File # MH48829

Canadian Registration Number

CRN: 8949.7980YTN

## **TRADEMARKS**

The Clean Energy logo is a registered trademark of Clean Energy Heating Systems, LLC.

## **COPYRIGHT**

Copyright © 2023 Clean Energy Heating Systems, LLC. This manual may not be reproduced or distributed without the prior written permission of:

Clean Energy Heating Systems, LLC.

PO Box 1341

479 Maple Street

Honey Brook, PA 19344

Subject to change without notice

# TABLE OF CONTENTS

|  |    |
|--|----|
| SAFETY CONSIDERATIONS AND GUIDELINES.....                | 4  |
| TIPS FOR MAINTAINING HIGH PERFORMANCE.....               | 6  |
| REMOVING ITEMS FROM THE COMBUSTION CHAMBER.....          | 7  |
| MOVING THE BOILER INTO POSITION .....                    | 7  |
| BOILER ASSEMBLY.....                                     | 8  |
| (1) Installing the combustion chamber sleeve.....        | 8  |
| (2) Installing the burner.....                           | 9  |
| (3) Installing the connector block and oil line.....     | 10 |
| BOILER INSTALLATION.....                                 | 11 |
| (1) Selecting a location.....                            | 12 |
| (2) Mounting the boiler in position.....                 | 13 |
| (3) Connecting the electrical supply.....                | 13 |
| (4) Installing the chimney components.....               | 14 |
| (5) Oil storage tank set up .....                        | 17 |
| (6) Installing the metering pump and oil lines.....      | 17 |
| (7) Connecting the compressed air line.....              | 22 |
| (8) Installing the wall thermostat.....                  | 22 |
| (9) Disign and Installation of the Hydronics System..... | 23 |
| (10) Inspecting the Boiler Installation.....             | 25 |
| BOILER CONTROLS AND SAFETY COMPONENTS.....               | 26 |
| PREPARING THE METERING PUMP FOR START UP.....            | 26 |
| STARTING AND ADJUSTING THE BURNER.....                   | 27 |
| (1) Preparing the burner for start up.....               | 27 |
| (2) Priming the oil pump.....                            | 27 |
| (3) Adjusting the Burner.....                            | 27 |
| RESETTING THE OIL PRIMARY CONTROL.....                   | 28 |
| SETTING THE DRAFT.....                                   | 29 |
| MAINTENANCE.....   | 30 |
| SEQUENCE OF OPERATION.....                               | 34 |
| BOILER DIMENSIONS.....                                   | 35 |
| WIRE DIAGRAMS.....                                       | 35 |
| BURNER POWER SWITCH.....                                 | 37 |
| PARTS DIAGRAMS.....                                      | 38 |
| CHIMNEY INSTALLATION DIAGRAMS.....                       | 48 |
| SERVICE RECORDS.....                                     | 50 |
| APPENDIX A .....   | 52 |
| (1) Domestic Hot Water Coil Installation.....            | 52 |
| WARRANTY INFORMATION.....                                | 53 |

# SAFETY CONSIDERATIONS AND GUIDELINES

## HAZARD DEFINITIONS:

**NOTICE:** Intended to clarify or bring special attention to previous information.



**CAUTION:** Indicates a hazardous situation, which can result in minor or moderate personal injury if not avoided.



**WARNING:** Indicates a hazardous situation, which can result in death or serious personal injury if not avoided.



**DANGER:** Indicates a hazardous situation, which will result in death or serious personal injury if not avoided.

## SAFETY CONSIDERATIONS:



**WARNING:** Incorrect installation, adjustment, or misuse of this heating equipment could result in death, severe personal injury, or substantial property damage.

### **To the Equipment Owner:**

- Read and understand all instructions provided in this manual
- Installation and service must be completed by qualified personnel who are familiar with oil-fired appliances.
- Save this manual for future reference.

### **To the Professional, Qualified Installer or Service Agency:**

- Read and carefully follow all instructions provided in this manual before installing, starting, or servicing this heating equipment.
- All installations must be made in accordance with state and local codes having jurisdiction.



**DANGER:** DO NOT store or use gasoline or other flammable/explosive liquids/vapors in or around the boiler.



**DANGER:** DO NOT operate the boiler if excess oil, oil vapors, or fumes have accumulated in or around the boiler.



**DANGER:** Improper installation, operation, or maintenance of the boiler may create a fire or explosion hazard.



**WARNING:** DO NOT mix unapproved substances to the used oil supply, such as:

- Anti-Freeze
- Carburetor Cleaner
- Paint Thinner
- Parts Washer and/or Solvents
- Gasoline
- Oil Additives
- Chlorinated solvents
- Any other inappropriate / hazardous material

Instruct your personnel **NEVER** to add unapproved substances to your used oil.

Burning any unapproved substance will immediately **void the boiler warranty** and may cause damage and unsafe operating conditions.



**WARNING:** Unauthorized boiler modifications may cause damage and unsafe operating conditions.

# SAFETY CONSIDERATIONS AND GUIDELINES



**WARNING:** The CE-4 Burner is only approved for use on heating equipment manufactured by Clean Energy Heating Systems. The boiler is only approved for use with the CE-4 burner manufactured by Clean Energy Heating Systems.



**WARNING:** The installation, operation, and maintenance of this equipment in the United States must be done by qualified personnel according to instructions in the Clean Energy Heating Systems Owner's Manual and in accordance with all national, state, and local codes or authorities having jurisdiction and the following standards:

|                 |  |
|-----------------|--|
| ASME Section IV | Boiler Code for Pressure Vessels                               |
| ASME CSD-1      | Controls and Safety Devices for Automatically Fired Boilers    |
| NFPA 30         | Flammable and Combustible Liquids Code                         |
| NFPA 30A        | Automotive and Marine Service Station Code                     |
| NFPA 31         | Installation of Oil Burning Equipment                          |
| NFPA 70         | National Electrical Code                                       |
| NFPA 88A        | Parking Structures   |
| NFPA 88B        | Repair Garages   |
| NFPA 211        | Chimney's, Fireplaces, Vents and Solid Fuel Burning Appliances |

Likewise, the installation, operation, and maintenance of this equipment in Canada must be done by qualified personnel according to instructions in the Clean Energy Heating Systems Owner's Manual and in accordance with all regulations and authorities having jurisdiction and the following CSA Standards:

|          |   |
|----------|---|
| B139     | Installatin Code for Oil Burning Equipment                              |
| B140.0   | General Requirements for Oil Burning Equipment                          |
| B140.7.2 | Oil Fired Steam and Hot Water Boilers for Commercial and Industrial Use |
| B214     | Installation Code for Hydronic Heating Systems                          |
| C22.1    | Canadian Electrical Code, Part 1  |

## GUIDELINES FOR BOILER USE:

- This boiler is for industrial and/or commercial use only. This boiler is not intended for residential use.
- Clean Energy Heating Systems boilers are listed with Underwriters Laboratories (UL) in the U.S. and Canada to burn the following fuels:
  - #2 fuel oil\*
  - Used crankcase oil up to 50 SAE
  - Used hydraulic oil
  - Used automatic transmission fluid (U.S.)
- The EPA regulations for burning used oil are as follows:
  - Your supply of used oil is generated on-site. You may also collect oil from "do-it-yourself" oil changers.
  - Do not mix hazardous wastes, such as chlorinated solvents, with your used oil.
  - The exhaust gases of the heating equipment must be vented to the outside with an appropriate stack system.
  - The boiler is used to recycle used oil for "heat recovery". The boiler is not to be used in warm weather just to dispose of used oil.
- Only trained authorized personnel should service and maintain the boiler. Be sure the boiler receives annual maintenance to ensure safe and efficient operation.

\* #2 Fuel Oil (Diesel Fuel) should be mixed with other used oil to increase the viscosity and allow proper fuel delivery.

# SAFETY CONSIDERATIONS AND GUIDELINES

## ADDITIONAL GUIDELINES FOR CANADIAN INSTALLATIONS:

NOTICE: This appliance has been evaluated to electrical and fuel-burning requirements only.

- (1) The installation, including stack height requirements and distance from property lines, shall be in accordance with the authorities having jurisdiction concerning environmental quality, as well as fuel, fire, and electrical safety and Table 7 in CSA B140.0-03.
- (2) The structure in which the boiler is housed shall be no less than 4.6 m (15 ft) high at the point where the boiler is situated and have a minimum length and width of 6 m (20 ft) and a minimum floor area of 37 m<sup>2</sup> (400 ft<sup>2</sup>).
- (3) Every month, the fire side of the heat exchanger and flue piping must be cleaned.
- (4) Every month, the oil-feed reservoir must be cleaned.
- (5) Every year, the exhaust stack must be cleaned.
- (6) Whenever any cleaning, including that of the flue piping and exhaust stack, is done, proper protective clothing including gloves and a face mask or respirator must be worn.
- (7) Keep the fuel valve nearest to the supply tank shut off when the burner is shut off for extended periods.

 **CAUTION:** Used oils contain heavy metallic compounds and foreign materials. When burned, these compounds are emitted from or deposited within this heating appliance and therefore care should be taken when using, cleaning and maintaining this equipment.

## GUIDELINES FOR USED OIL TANKS:

 **WARNING:** To avoid serious injury or death, only store the following substances in the oil supply tank:

- (1) Used Crankcase Oil
- (2) Used Automatic Transmission Fluid (ATF)
- (3) Used Hydraulic Oil
- (4) #2 Fuel Oil (Diesel Fuel)\*

\* #2 Fuel Oil (Diesel Fuel) should be mixed with other used oil to increase the viscosity and allow proper fuel delivery.

DO NOT put flammable or corrosive substances such as gasoline, chlorinated solvents, paint thinner, or any other unsafe substance in the oil supply tank.

 **WARNING:** Waste oil may contain gasoline. Take precaution when handling and storing waste oil.

 **WARNING:** To avoid serious injury or death, do not weld or allow open flames within 35 feet of the used oil supply tank.

- (1) The tank installation must comply with NFPA 30 and NFPA 31 fire codes.
- (2) The tank should be installed on a slight slope with a drain on the low end to allow sludge and water to be removed from the bottom of the tank.
- (3) All oil lines must be constructed of copper, steel, or brass components. DO NOT use rubber, plastic, or any other inappropriate material for oil lines.
- (4) Be sure to follow all instructions for tank installation in the Owner's Manual.

## TIPS FOR MAINTAINING HIGH PERFORMANCE

**DO NOT ALLOW ANY UNAPPROVED MATERIAL INTO THE OIL STORAGE TANK.**

*Material placed in the oil storage tank will eventually be delivered to the burner. Antifreeze and water will not ignite and will cause the heating equipment to shut down.*

## TIPS FOR MAINTAINING HIGH PERFORMANCE

### TURN OFF POWER TO THE BURNER IF A CALL FOR HEAT IS NOT EXPECTED FOR MORE THAN A WEEK.

If the green power light is "on" at the burner, the oil temperature is being maintained by the 200W heater element. If this oil temperature is maintained over a long period of time (like over the summer months) without a call for heat, the nozzle adapter heater block is more likely to accumulate carbon build up which may cause a plugged nozzle. Flip the breaker "off" at the panel or turn the Burner Power Switch "off" located in the junction box on top of the unit.

### DO NOT USE EXHAUST FANS THAT CREATE A VACUUM IN THE BUILDING.

A backdraft at the heating equipment will damage critical burner components. If your shop requires exhaust fans there must be adequate make up air so that the unit can maintain a proper natural draft. If there is insufficient make up air, install make up air louvers or use a relay to open the wall thermostat circuit to ensure the burner does not fire when an exhaust fan is in use.

## REMOVING ITEMS FROM THE COMBUSTION CHAMBER

- (1) Remove the four nuts from the front door.
- (2) Carefully swing the front door open.
- (3) Remove the items packed inside the combustion chamber.
- (4) Leave the door open to install the combustion chamber sleeve as instructed later in this manual.

## MOVING THE BOILER INTO POSITION



**WARNING:** Because of the weight and size, take extreme care when moving the boiler.

- (1) Refer to Figure 1.
- (2) There are two angles 24" apart to allow for easy lifting.
- (3) The boiler can be lifted from either side with a forklift or pallet truck.
- (4) The boiler can also be lifted from either the front or back. The legs are spaced 27" apart which allows the use of a standard pallet truck.

**NOTICE:** To reduce the chance of damage, move the boiler into position before installing the burner.

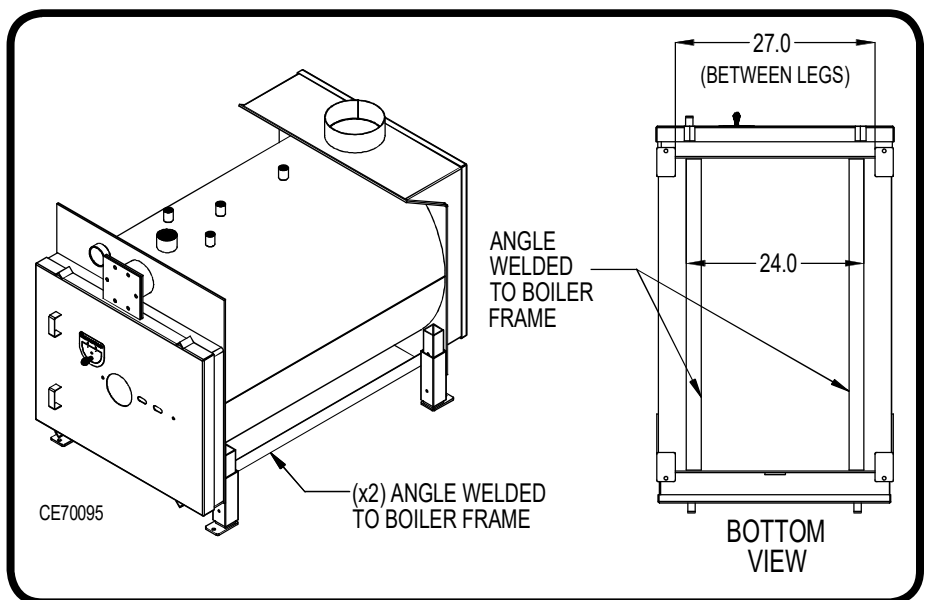

Figure 1: Boiler Shown Without Shrouding To Reveal Lifting Points

# BOILER ASSEMBLY

Follow the steps below for boiler assembly (refer to Figure 2):

- (1) Install the combustion chamber *sleeve*
- (2) Install the *burner*
- (3) Install the *connector block* and *oil line*

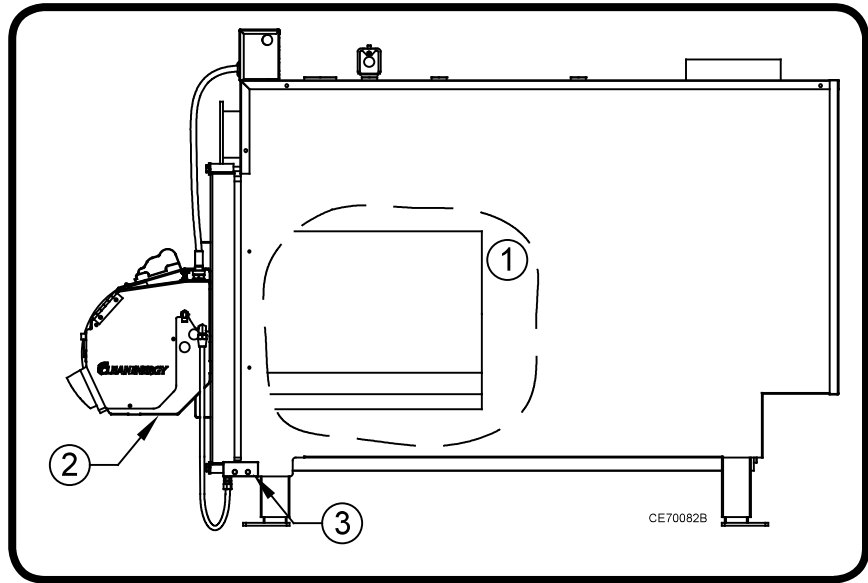

Figure 2: Typical Boiler Assembly

## Installing the Combustion Chamber Sleeve:

**NOTICE:** Improper combustion may occur if the boiler is used with a damaged or missing combustion sleeve. Inspect the combustion sleeve regularly for proper positioning and wear.

- (1) Refer to Figures 3 and 4 to view the proper position of the combustion chamber sleeve.
- (2) Open the front door of the boiler by loosening the four bolts and swinging the door open.
- (3) Place the 3"x3"x20" support blocks on the bottom of the combustion chamber as shown.
- (4) Place the combustion chamber sleeve on top of the support blocks and flush with the front door.
- (5) Close the front door and secure the four bolts.

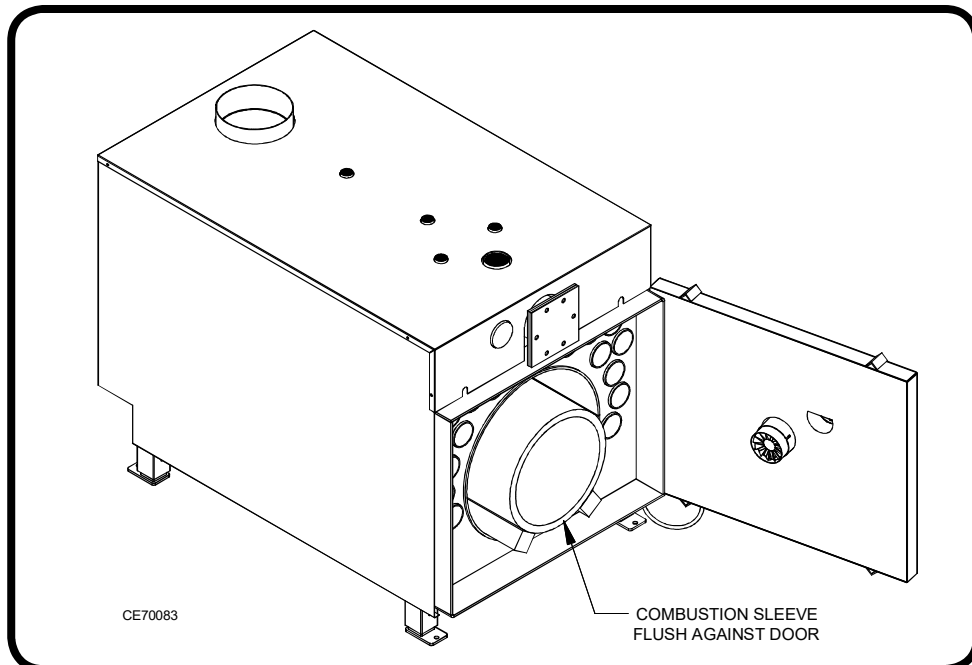

Figure 3: Proper Position of the Combustion Chamber Sleeve



# BOILER ASSEMBLY

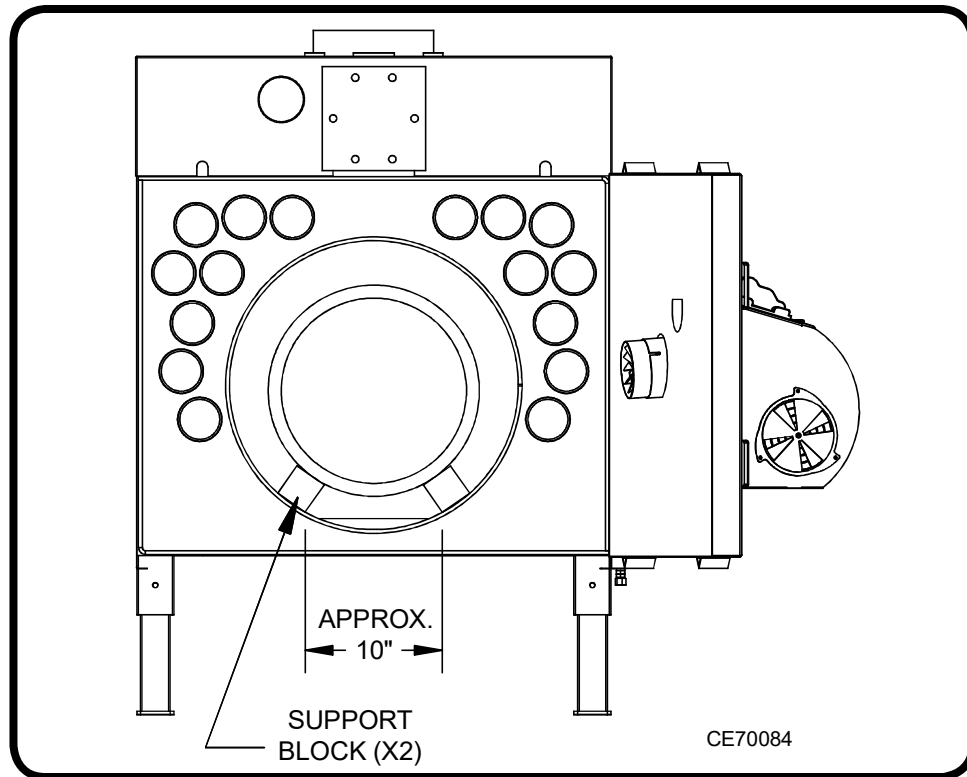

Figure 4: Combustion Chamber Sleeve Location

## Installing the Burner:

**NOTICE:** The nozzle, electrode, and retention head may need adjustment after shipping and installation. The nozzle should remain centered in the retention head. Refer to Figure 5 for proper dimensions.

- (1) Remove the two serrated flange nuts from the front door.
- (2) Slide the blast tube of the burner through the throat of the front door.
- (3) Fasten the burner to the front door by tightening the two serrated flange nuts.

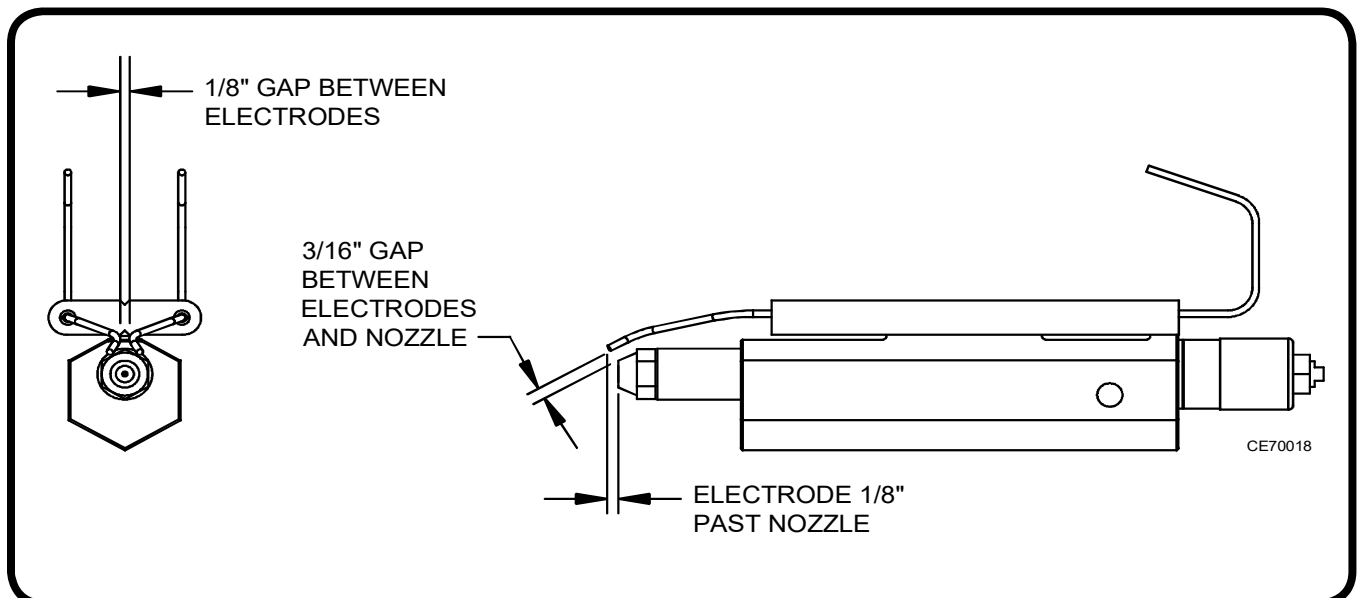

Figure 5: Nozzle and Electrode Settings

## BOILER ASSEMBLY



**WARNING:** To prevent the risk of electrical shock, shut OFF main power to the boiler before connecting or disconnecting the burner power cord.

- (4) Refer to Figure 6
- (5) Line up the key in the receptacle with the slot in the cord.
- (6) Tighten the electrical cord when in position.

**NOTICE:** Make sure the plug and receptacle are properly aligned. The ground prong in the receptacle is longer than the other prongs and must be lined up properly.

### Installing the Connector Block and Oil Line:

- (1) Refer to Figure 7 to position the connector block.
- (2) Fasten the connector block to the side of the boiler with the bolts provided.
- (3) Install the supplied 3/8" copper tubing from the swivel fitting in the connector block to the burner.

**NOTICE:** The connector block with the swivel fitting must be used to allow the front door to swing open properly. If the connector block is not used the oil line will need to be disconnected before the door is opened.

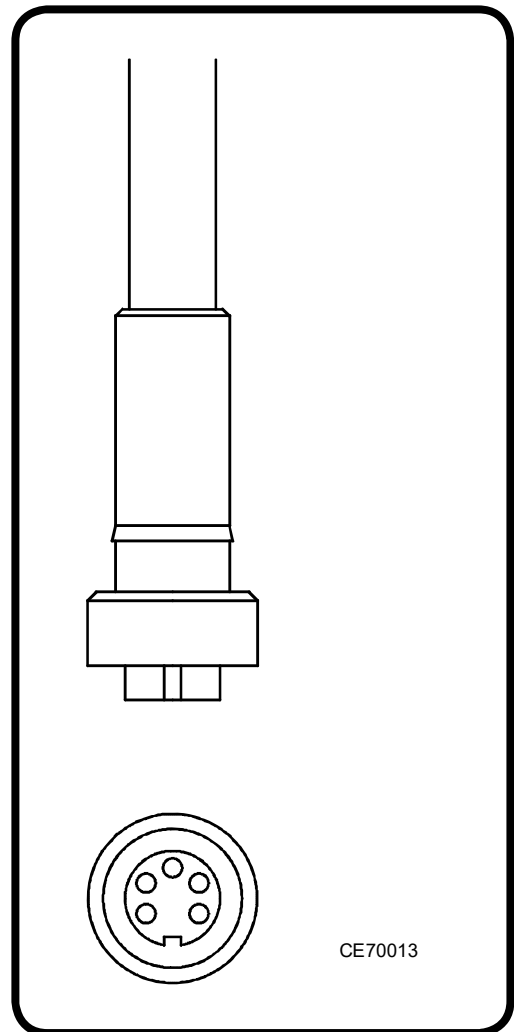

Figure 6: Installing the Burner Cord

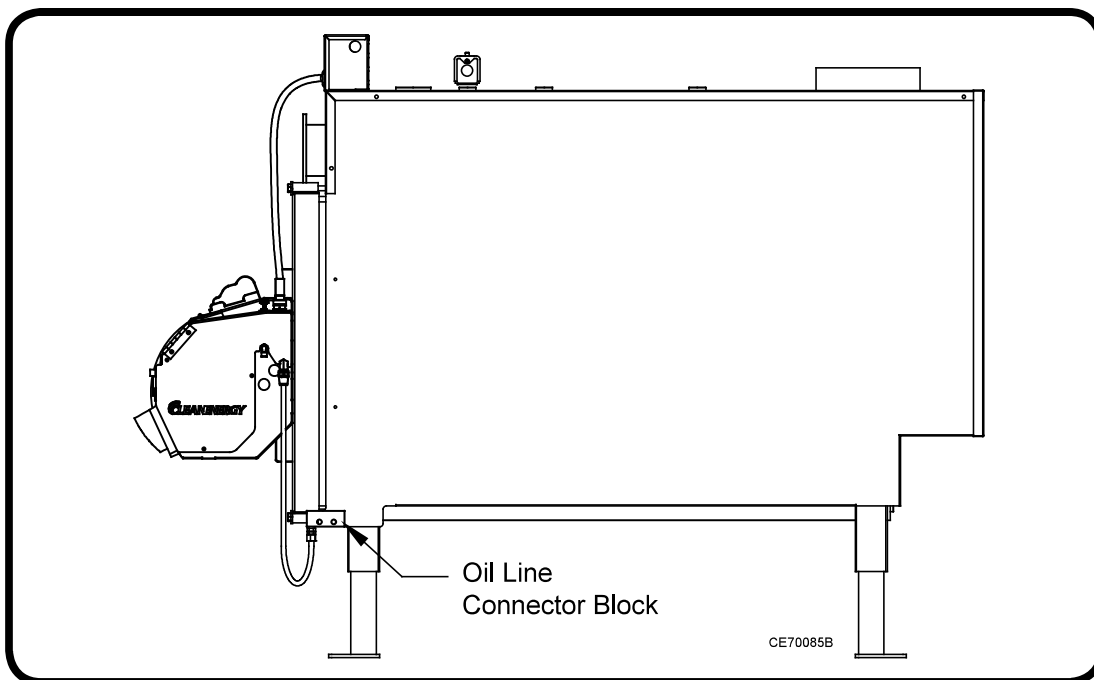

Figure 7: Installing the Connector Block and Oil Line

# BOILER INSTALLATION

Refer to Figure 8 for a typical boiler installation illustration.

Installation of your boiler will include the following steps:

- (1) Selecting a location
- (2) Mounting the boiler in position
- (3) Connecting the electrical supply
- (4) Installing the chimney components
- (5) Positioning the oil storage tank
- (6) Installing the metering pump and oil lines
- (7) Connecting the compressed air line
- (8) Installing the wall thermostat
- (9) Design and Installation of hydronics system
- (10) Inspecting the boiler installation

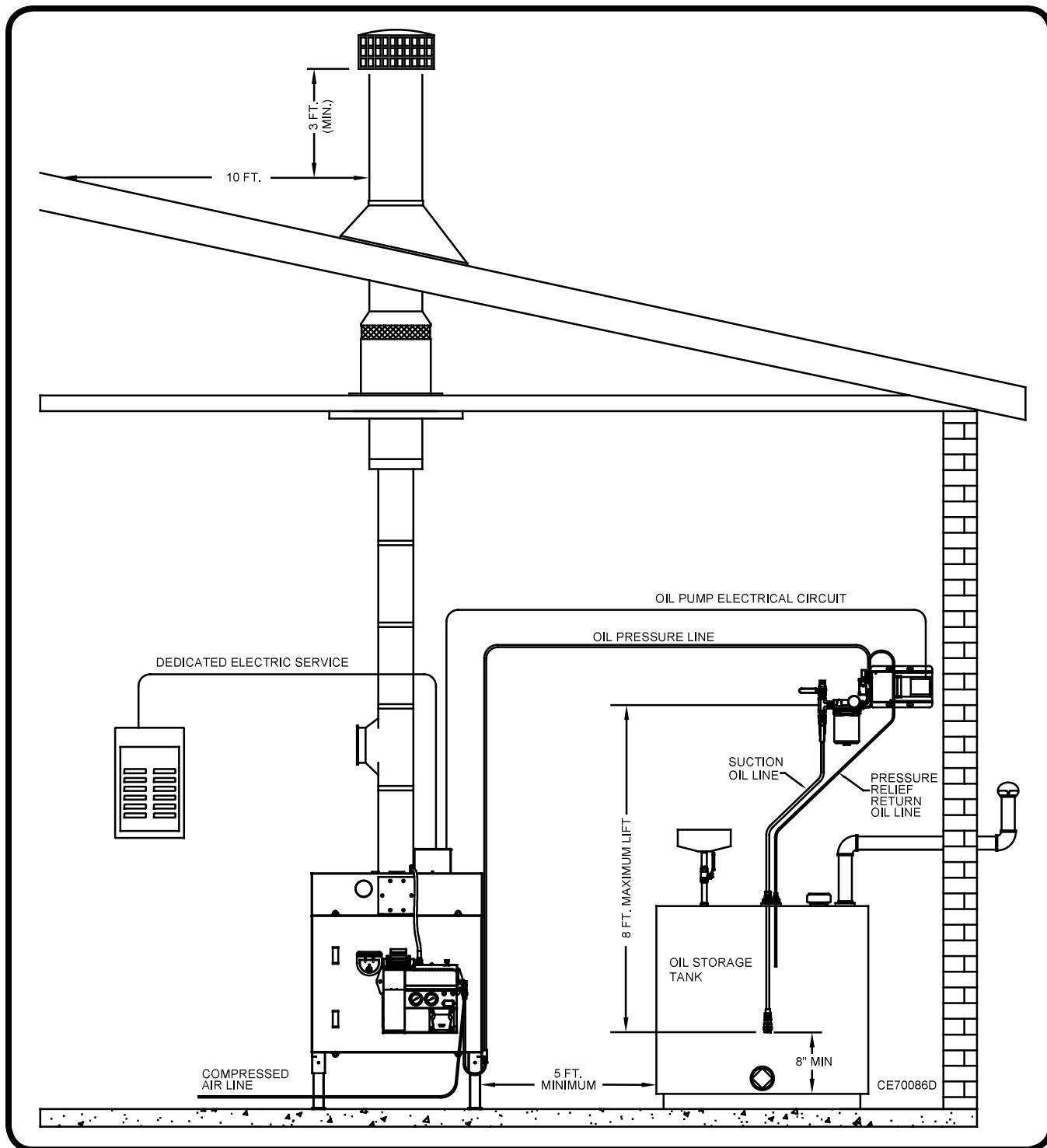

Figure 8: Typical Boiler Installation

# BOILER INSTALLATION



**WARNING:** Carefully follow all installation instructions for safe and efficient operation.

## Select a location:

There are several considerations when selecting a location for the boiler:

- (1) Do not obstruct shop personnel or equipment
- (2) Find a location where the boiler can easily be moved into place.
- (3) The installation must meet the clearance to combustible material requirements (Figure 9)
- (4) The location must be safely accessible for maintenance and service
- (5) The installation must comply with all local codes and regulations
- (6) Keep the stack / chimney system simple. A complicated stack with multiple elbows and long horizontal runs will reduce the natural draft of the unit which can damage critical burner components.

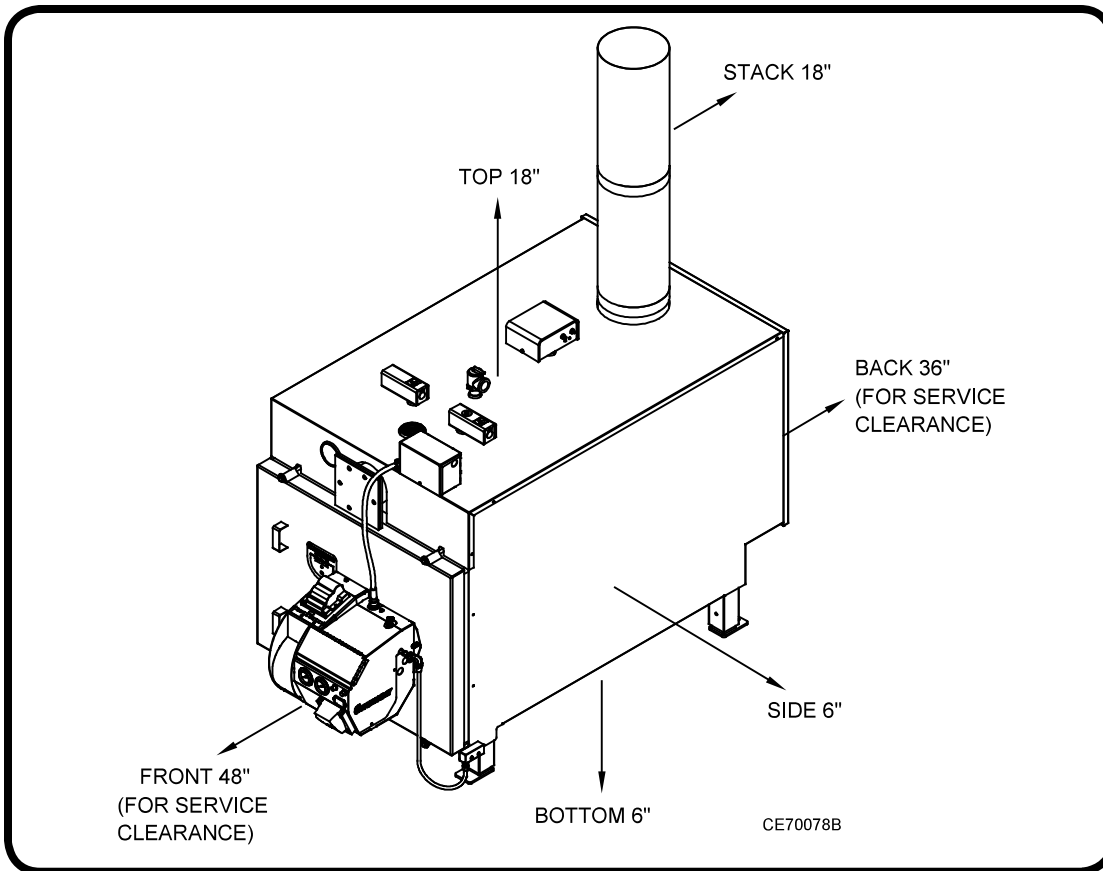

## Minimum Distances from Combustible Materials

### CE-340 BOILER

|                    |                                 |
|--------------------|---------------------------------|
| Front (Burner)     | 18" (48" for service clearance) |
| Back               | 18" (36" for service clearance) |
| Side               | 6"                              |
| Top                | 18"                             |
| Chimney Connection | 18"                             |

# BOILER INSTALLATION

## Mounting the Boiler in position:



**WARNING:** The floor or pad for boiler installation must support the weight of the boiler when it is full of water. A level concrete floor or pad is recommended.

- (1) Refer to Figure 8 for a typical installation.
- (2) Set the boiler in position.
- (3) Raise the four legs up if desired.
- (4) Fasten the four legs to the floor through the holes in the pads on the bottom of each leg.
- (5) Use a level to ensure the boiler is level front-to-back and side-to-side.

## Connecting the electrical supply to the Boiler:



**WARNING:** Shut off main power to the boiler before making any electrical connections. ONLY a qualified electrician should run wire and make connections to the boiler. All wires must be the proper gauge and run in approved electrical conduit. All wiring must meet the requirements of the National Electrical Code.

Electrical Requirements:

120 V / 60 Hz  
Single Phase  
20 Amp dedicated circuit

- (1) Install a dedicated electrical circuit to the junction box above the burner.
- (2) Connect the wires according to the label found on the inside of the junction box cover or in the *wire diagrams section* of this manual. Use stranded copper wire to ensure a secure connection.

# BOILER INSTALLATION

## Installing the chimney components:



**DANGER:** Follow manufacturers instructions and requirements for clearances (air spaces) to combustible material for the Double Wall “Class A” Insulated chimney material.



**WARNING:** UL “Class A” All Fuel Approved to 2100°F Chimney (UL - 103 HT Approved) must be used through any building penetration and for any exterior stack. Unapproved stack material and/or installation can create a fire hazard. Contact Clean Energy Heating Systems, LLC to purchase approved stack material for your installation.



**CAUTION:** Using single wall stack on the exterior of your building will cause the stack gases to cool rapidly and adversely affect the natural draft of the boiler. This will create a back draft and may damage critical burner components.

- (1) Refer to Figure 10 for a typical through-the-roof chimney illustration and Figure 11 for a typical through-the-wall chimney illustration.
- (2) Observe the following requirements when installing the chimney:
  - The CE-340 boiler requires 8” I.D. stack components.
  - Have a minimum of 10 feet vertical chimney to ensure -.02” w.c. draft over fire.
  - Keep horizontal runs short. Slope any horizontal sections at least 1/4” per foot.
  - Keep the stack installation simple. Multiple turns and horizontal runs will reduce the natural draft of the boiler which may damage critical burner components.
- (3) Single wall stack may be used inside the building. Observe proper clearances from combustibles. Do not put single wall stack in areas that may create a burn hazard to personnel.
- (4) Install a barometric damper, as shown in Figures 10 and 11, so that proper draft can be maintained. Follow the instructions provided with the damper for proper installation.
- (5) Use double wall “Class A” insulated stack when making a penetration through the roof or side wall of your building. Install proper flashing around the exterior penetration of the stack to make a water tight seal.
- (6) Install a “Class A” non-restrictive stack cap only.



**CAUTION: IF YOUR BUILDING UTILIZES AN EXHAUST FAN**, ensure that there is adequate make-up air available. Lack of make-up air will create a vacuum in your building which will result in a back draft at the boiler. A back draft will damage critical burner components. If there is insufficient make up air, install make up air louvers or use a relay to open the wall thermostat circuit to ensure the burner does not fire when an exhaust fan is in use.

# BOILER INSTALLATION

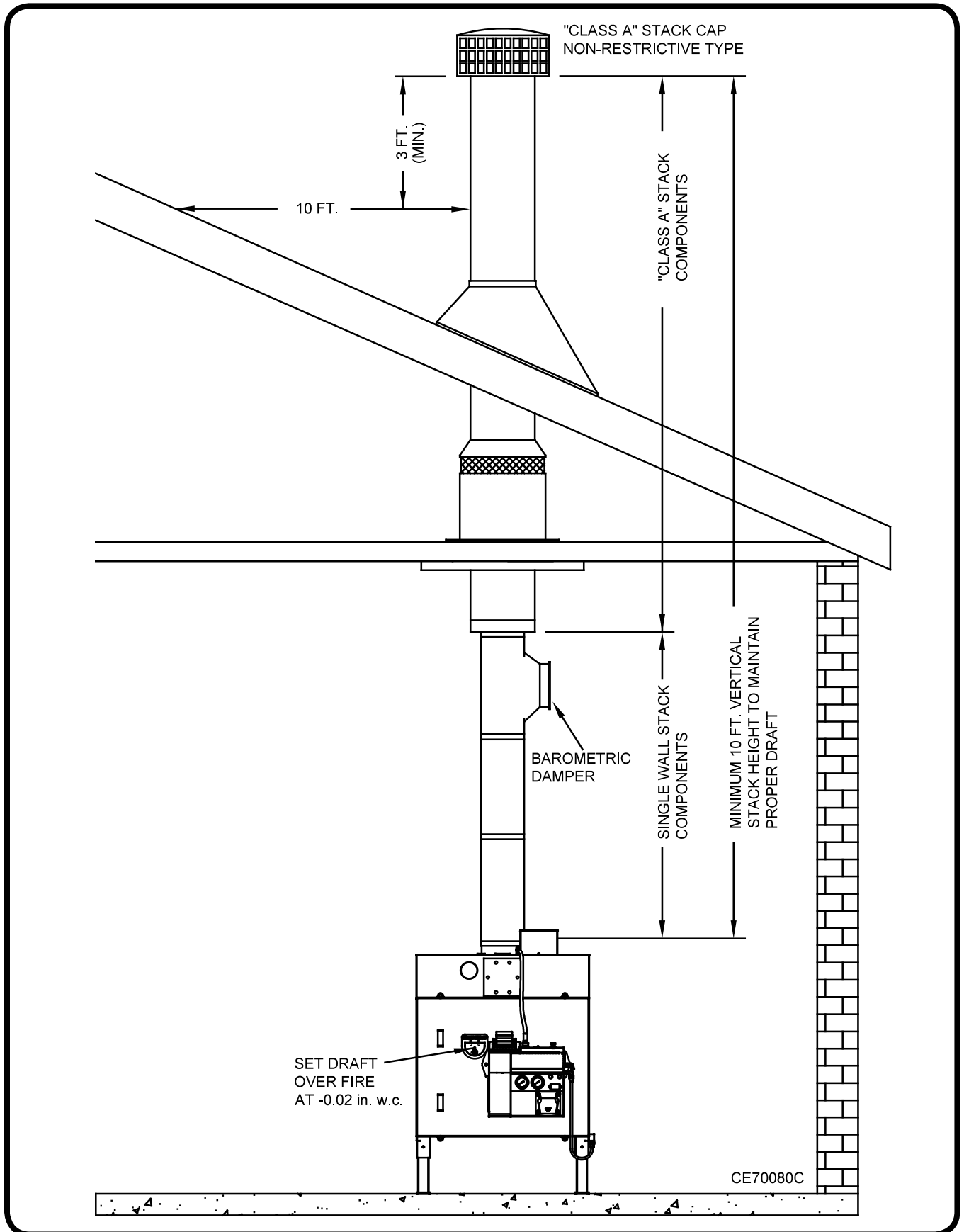

Figure 10: Typical Through-the-Roof Chimney Illustration

# BOILER INSTALLATION

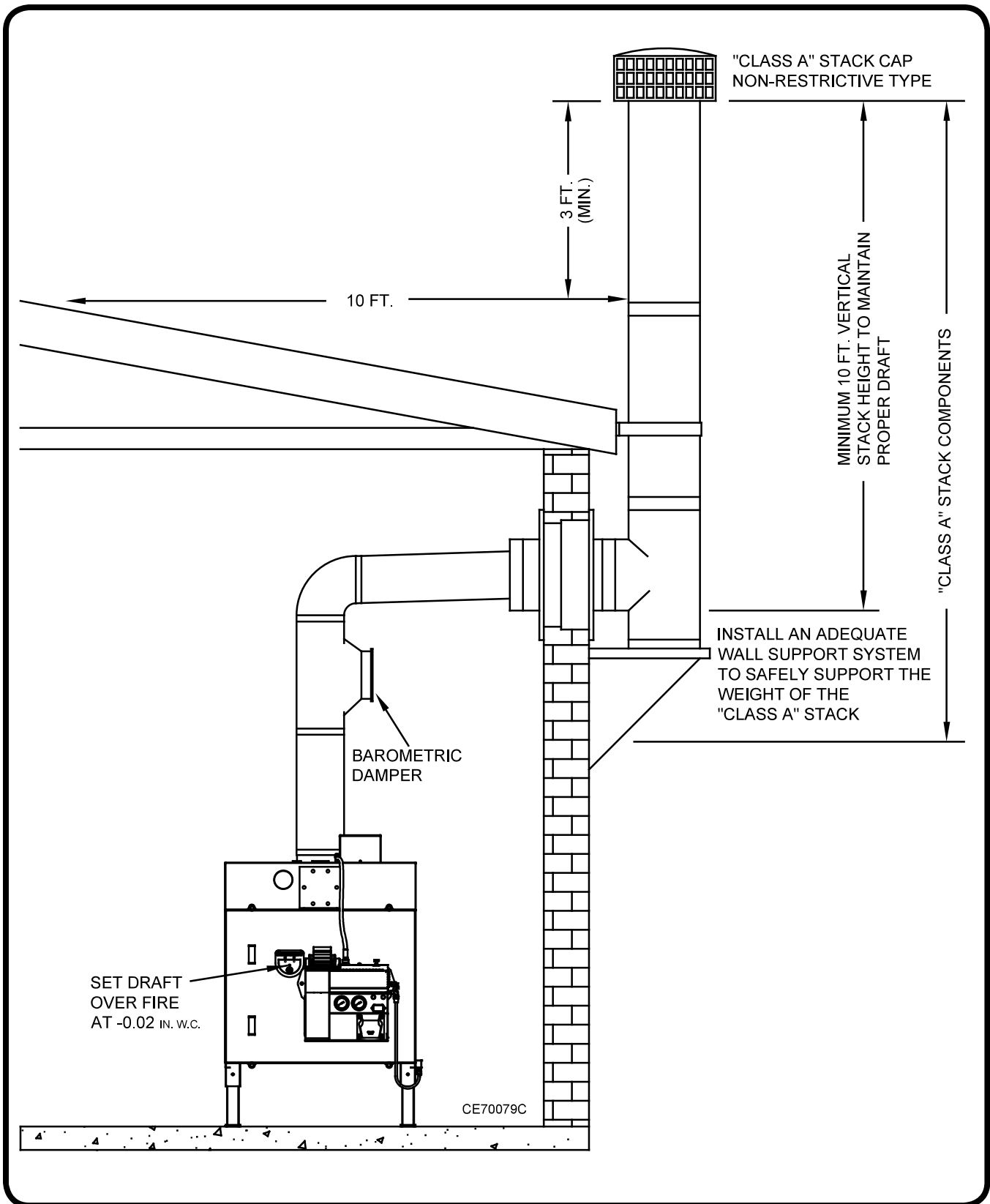

Figure 11: Typical Through-the-Wall Chimney Illustration



# BOILER INSTALLATION

## Oil storage tank setup:

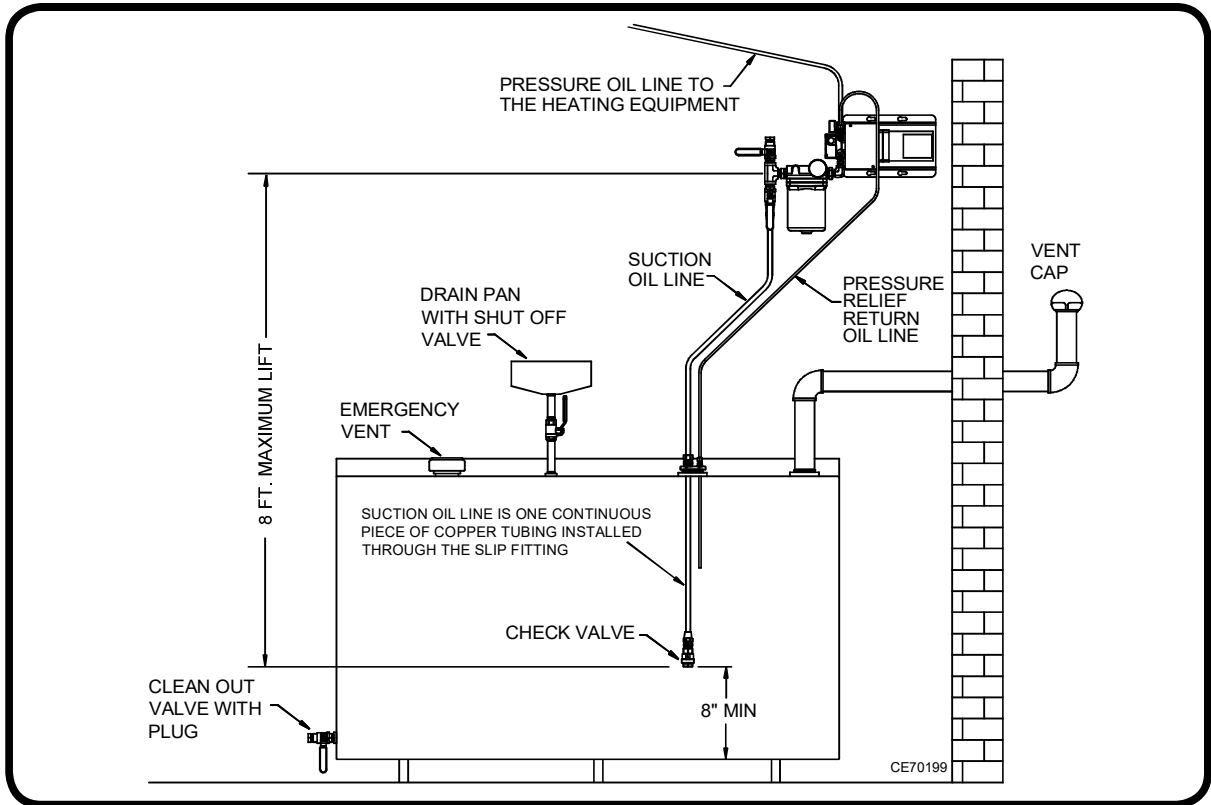

Figure 12: Typical Oil Storage Tank Installation

- (1) Refer to Figure 12 for a typical oil storage tank setup.
- (2) The tank must be installed according to all NFPA requirements and State and Local codes.
- (3) An inside tank is recommended.
- (4) Locate the tank in a position that will allow the oil pump to be mounted as close as possible
- (5) Only use a tank with a drain on the bottom. Over time, dirt and sludge will naturally accumulate on the bottom of the tank and there must be a way of removing this unwanted material.
- (6) Some state and local codes require the tank to be vented to the outside.
- (7) Educate all personnel what substances are allowed to be added to the used oil supply and apply the provided tank warning label near the fill location.

## Installing the metering pump system and oil lines:



**CAUTION:** The metering pump must be mounted above the oil tank. The pump is not designed to take head pressure. If the pump is below the level of oil in the tank the pump seals may begin to leak.

## Metering Pump Installation Guidelines:

- (1) Use non-hardening thread sealer for all threaded pipe fittings.

**NOTICE:** DO NOT use teflon tape on any oil or air fittings. The use of teflon tape on any fittings will VOID the warranty.

- (2) The pump must be installed with the shaft in the horizontal position and the oil outlet pointing up.

**NOTICE:** The gauge arrow on the front of the pump head must be pointing up.

# BOILER INSTALLATION

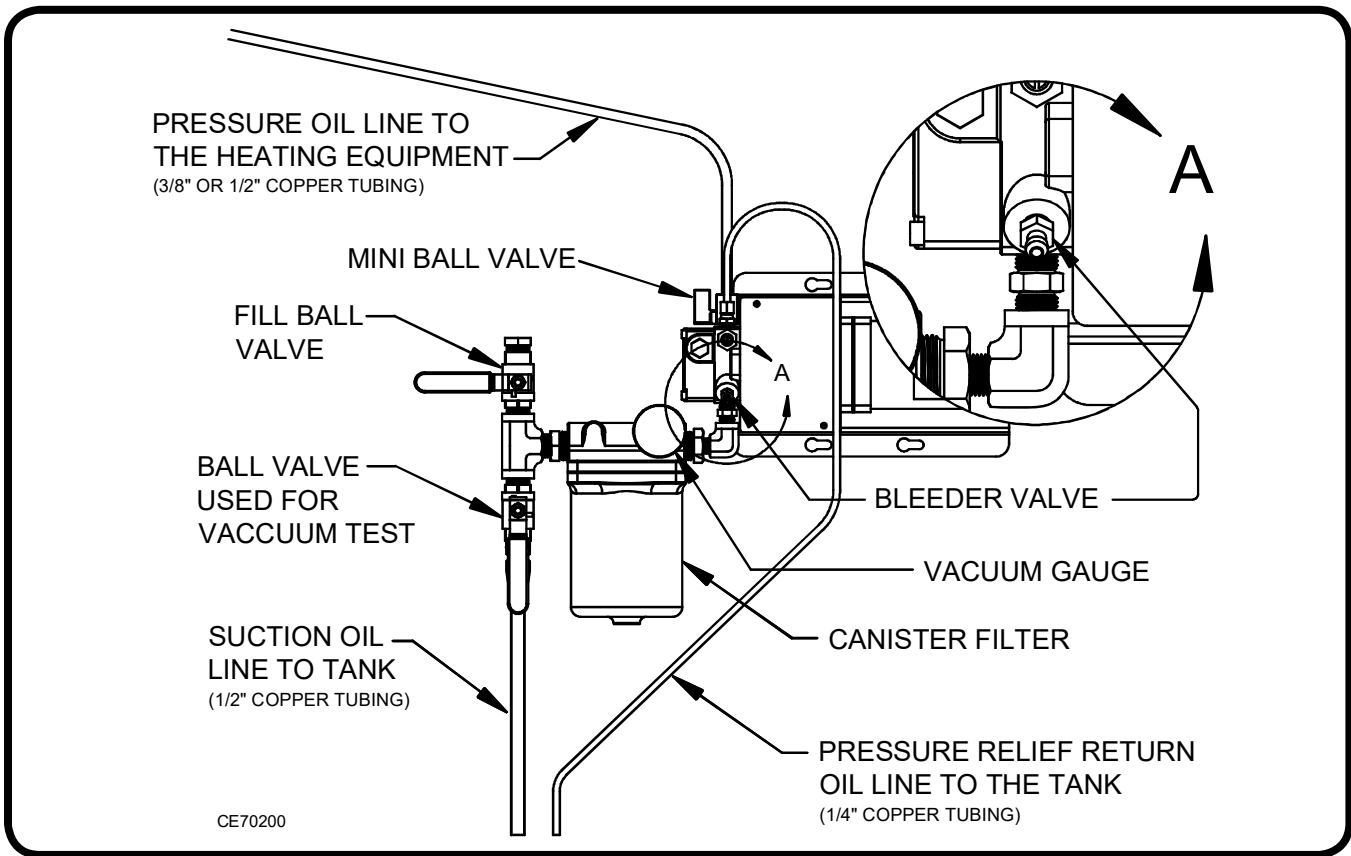

- (3) The metering pump system is a fixed displacement pump. The pump shaft is driven by a garmotor at a specific rpm, for each specific model. This delivers a constant flow (gph) of fuel. Change in oil viscosity and temperature have very little effect on fuel flow. Therefore no oil pressure adjustment is needed for the metering pump system.
- (4) The metering pump must be mounted as close to the tank as possible. The suction oil line (length of oil line from the bottom of the tank up to the pump) must not exceed 8 vertical feet. Every 3 horizontal feet of suction line reduces the maximum allowable vertical lift by 1 foot.
- (5) The suction oil line must be a minimum of 8" from the bottom of the tank to reduce the likelihood of sludge and/or water being delivered to the boiler.
- (6) The metering pump system is not weatherproof. Mount the pump indoors only.

## Mounting the metering pump assembly:

**NOTICE:** The metering pump system comes assembled for standard mounting on a wall.

### STANDARD MOUNTING:

- (1) Refer to Figure 13 for a typical metering pump installation (standard mounting on a wall).
- (2) Use appropriate hardware to mount the metering pump system to the wall.
- (3) Keep the pump assembly as close to the tank as possible.

### ALTERNATE MOUNTING:

- (1) Refer to Figure 14 for an illustration of the alternate horizontal mounting.
- (2) Loosen the pump head and rotate it 90°. The pump assembly may now be mounted in the horizontal position as on a shelf.

# BOILER INSTALLATION

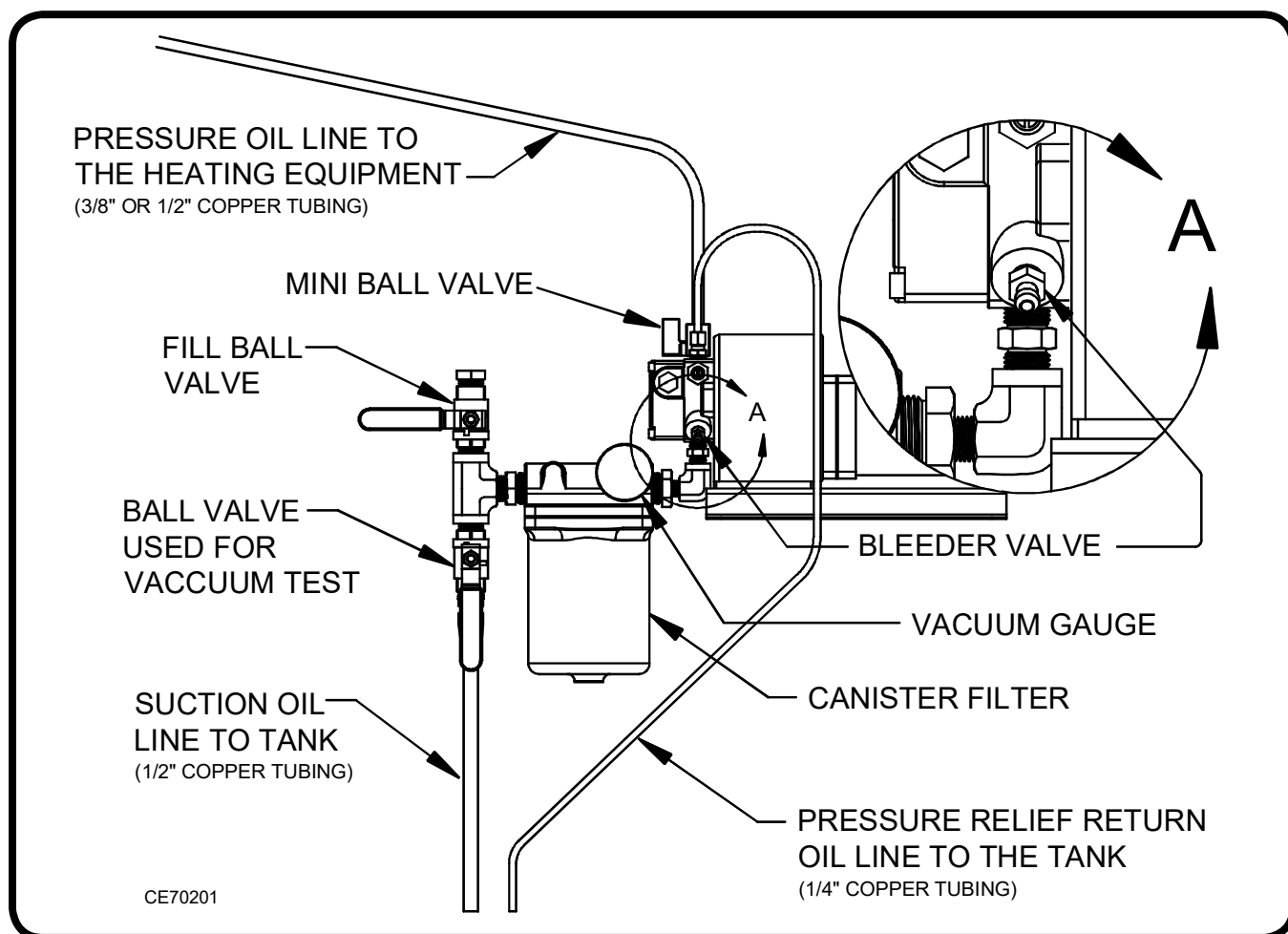

Figure 14: Alternate Horizontal Metering Pump Mounting

## Installing the suction oil line:

- (1) Refer to Figure 15.
- (2) Measure the height of the tank. Reduce this measurement by 8" and mark the 1/2" copper suction line tubing at this length.
- (3) Install the 1/2" MNPT slip-through fitting into the side of the 2" duplex fitting marked "S".
- (4) Slide the 1/2" copper suction line tubing through the slip fitting in the 2" duplex fitting up until the mark that was made indicating 8" less than the height of the tank.
- (5) Install the 1/2" flare fitting into the foot valve (arrow on foot valve pointing toward the flare).
- (6) Flare the 1/2" copper suction line tubing and install it on the foot valve.
- (7) Insert the suction tubing into the tank and tighten the 2" duplex fitting.
- (8) Carefully bend the 1/2" copper suction line tubing up to the filter and cut it to length.
- (9) Flare the 1/2" copper suction line tubing and install it on the filter.

## Installing the pressure relief oil line back to the tank:

- (1) Refer to Figure 15 and 16.
- (2) Install the 1/2" MNPTx1/4" compression fitting into the side of the 2" duplex fitting marked "R".
- (3) Run a piece of 1/4" copper tubing from the pump relief valve back to the tank.

# BOILER INSTALLATION

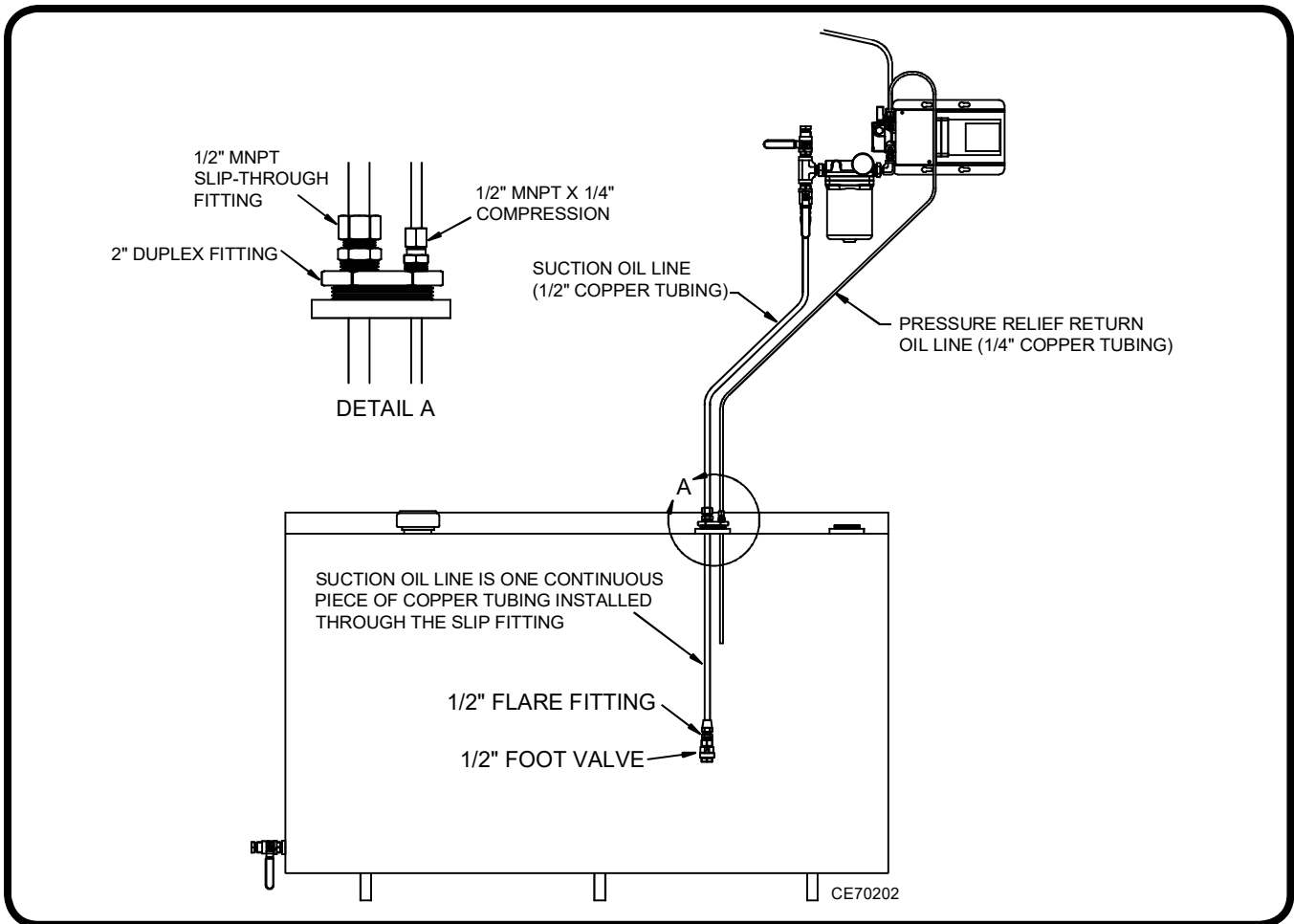

Figure 15: Installing the Suction Oil Line

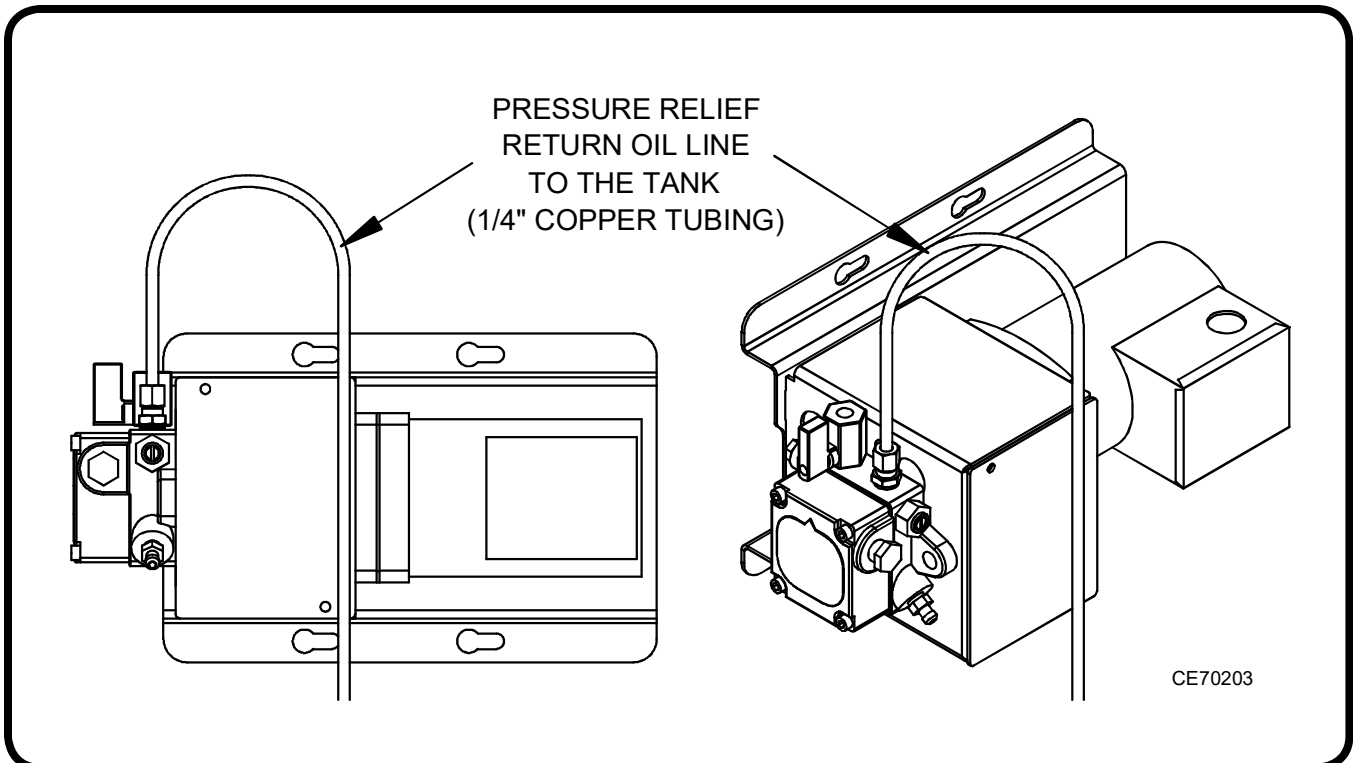

Figure 16: Metering Pump Pressure Relief Valve

# BOILER INSTALLATION

## Installing the pressure oil line to the boiler:

- (1) Refer to Figure 17.
- (2) Determine the length of copper tubing needed for the pressure line (from pump to boiler) and use the appropriate sized tubing. If the pressure line is less than 100 feet, 3/8" copper tubing can be used. If the pressure line is greater than 100 feet, use 1/2" copper tubing. An adapter fitting may be needed when using 1/2" copper to make the connection between the tubing fitting and mini ball valve (50039 - 1/8 MNPT x 1/4 FNPT).

**NOTICE:** There are installations that will operate well with a long pressure oil line. However, to ensure proper performance with variables such as oil temperature and viscosity, Clean Energy Heating Systems does not recommend exceeding 150 feet of total pressure oil line.

- (3) Refer to Figure 18.
- (5) Connect the pressure oil line to the aluminum connector block on the side of the boiler.

**NOTICE:** By connecting the oil line to the connector block, the swivel fitting is utilized which allows the front clean out door to be opened without disconnecting the oil line.

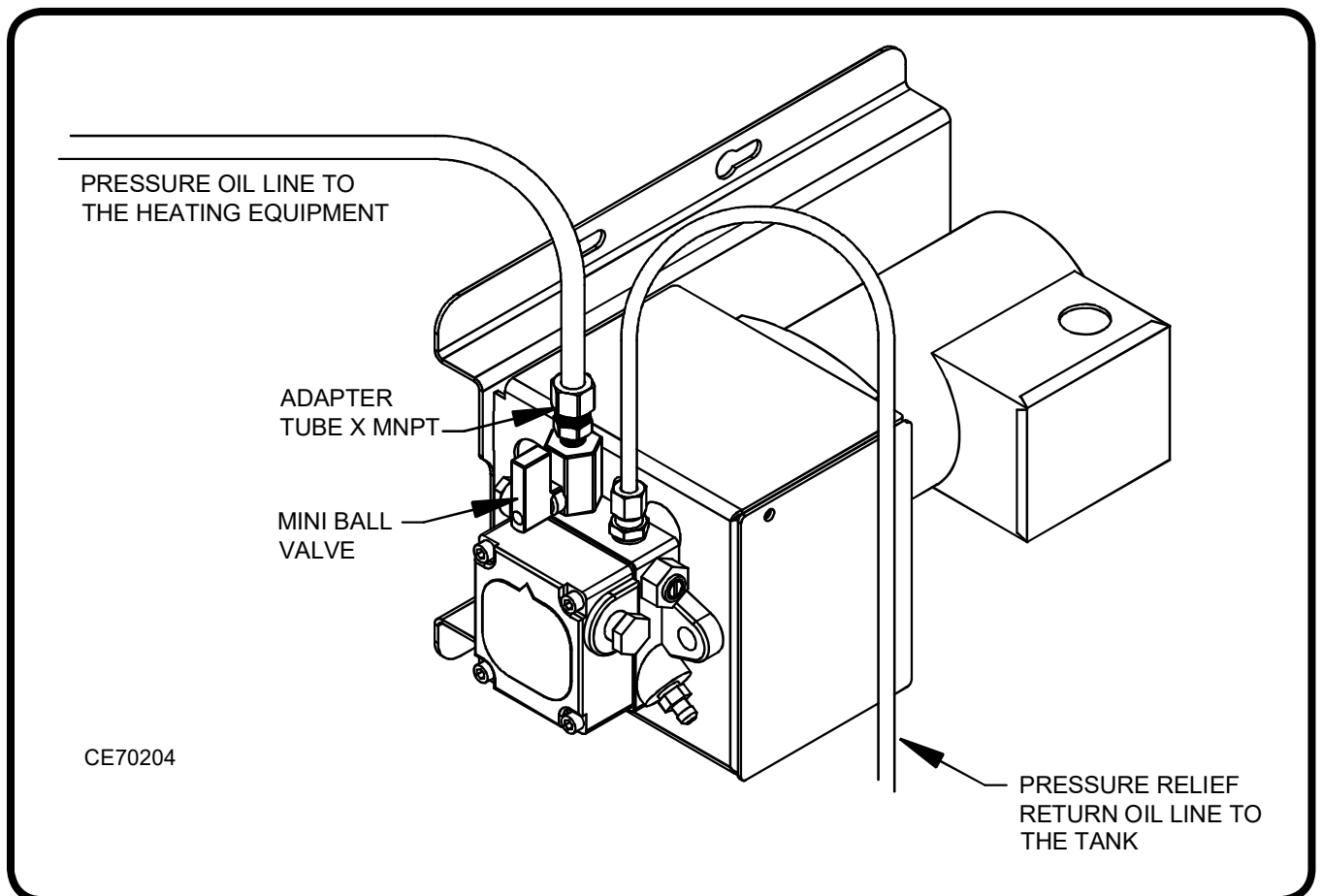

Figure 17: Metering Pump Oil Outlet Options

# BOILER INSTALLATION

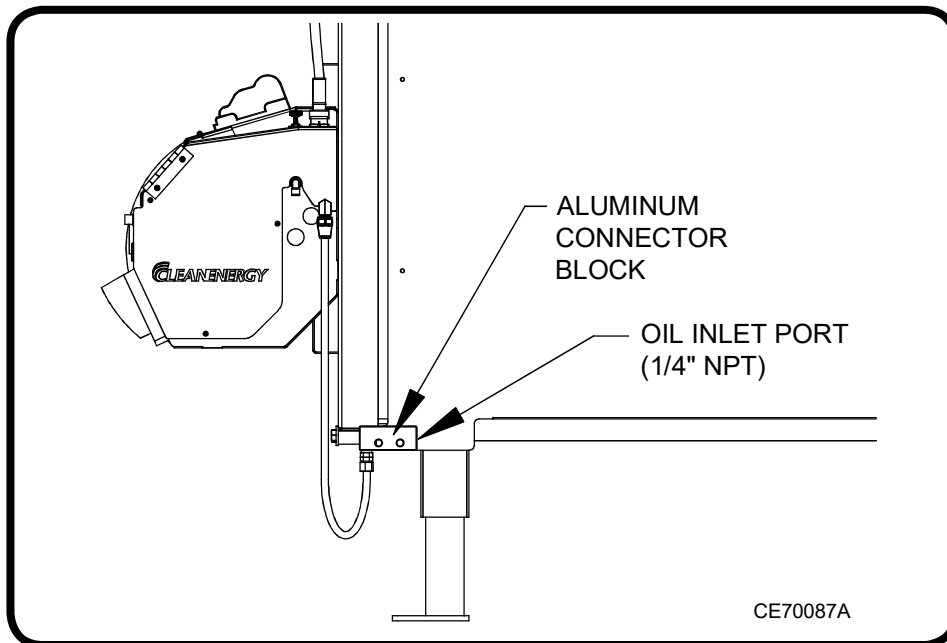

Figure 18: Connecting the Pressure Oil Line to the Connector Block

## Connecting the Compressed Air Line:

**NOTICE:** DO NOT use teflon tape on any oil or air fittings. The use of teflon tape on any fittings will VOID the warranty.

- (1) Refer to Figure 19.
- (2) mount a water trap / air regulator (adjusted to 50 psi) and shut-off valve close to the boiler.
- (3) Run a flexible hose to the air inlet on the side of the burner. Carefully secure the air line to ensure it does not come in contact with any hot metal surfaces.

**NOTICE:** If a flexible hose is not used the air line will need to be disconnected from the burner to swing the front door open.

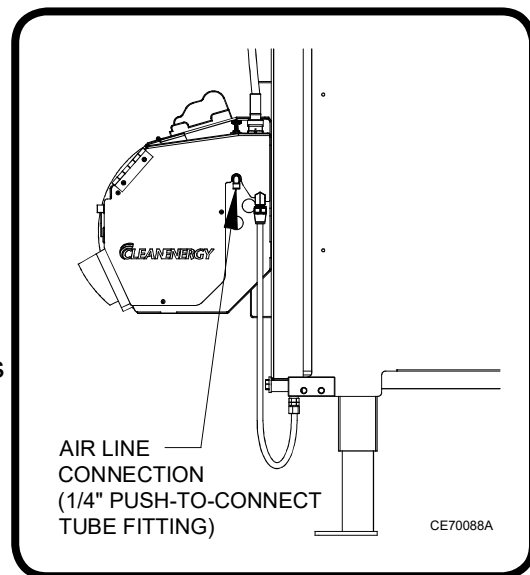

Figure 19: Installing the Air Line

## Installing the wall thermostat:

- (1) Use the digital wall thermostat provided with the boiler.
- (2) Mount the wall thermostat according to the instructions provided with the thermostat.
- (2) Mount the thermostat on an interior wall and in a location that will be shielded from drastic temperature changes such as a door being opened.
- (3) Mount the thermostat at eye level to allow for easy viewing and adjustment.
- (4) Run the thermostat cable from the wall thermostat to the T-T terminals on the oil primary control of the burner or to a switching relay. If a switching relay is used follow instructions with the switching relay for connecting the circulator pump and primary control.

## Changing the Wall Thermostat Batteries:

- (1) A low battery indicator will be displayed on the front screen to indicate low battery strength.
- (2) There is about a two week time frame to replace the batteries once the indicator comes on.
- (3) Follow instructions included with the thermostat to replace the batteries.

# BOILER INSTALLATION

## Design and Installation of the Hydronics System:

NOTE: Each install is unique. Contact your plumbing and hydronics expert to determine the layout and design of the system.

- (1) Water Temperature returning to the boiler must be above 140 °F. This will reduce condensation and thermal shock to the boiler.
- (2) The circulator should pump away from the expansion tank to reduce air problems.
- (3) Controls and valves must be used for multiple zones and for in floor heat to ensure the water temperature supplied to the floor is not too hot, and the water temperature returning to the boiler is not too cold.
- (4) The expansion tank must be sized according to the amount of water in the entire hydronics system. Take into account if antifreeze is added to the system.
- (5) Serious damage will occur if leaks occur in the hydronics system and excessive make-up water is being added. Make-up water will introduce oxygen which will lead to corrosion.
- (6) Incorporate an air separator and air vent to properly purge all air from the system to allow proper water circulation.
- (7) Refer to Figure 20. A water pressure safety relief valve must be installed (supplied with boiler). Run a pipe from the relief valve discharge to within four inches of the floor for safe pressure relief.
- (8) Refer to Figure 21 for typical single zone connections.
- (9) The Pressure Reducing Valve (Boiler Fill Valve) should be set at 12 psi.

## Recommended Boiler Control Settings:

|   |        |
|---|--------|
| Operating Aquastat                                | 180 °F |
| Operating Aquastat Differential                   | 20 °F  |
| High Limit Aquastat (Red Manual Reset Button)     | 200 °F |
| High Limit Aquastat Differential (Not Adjustable) | 20 °F  |

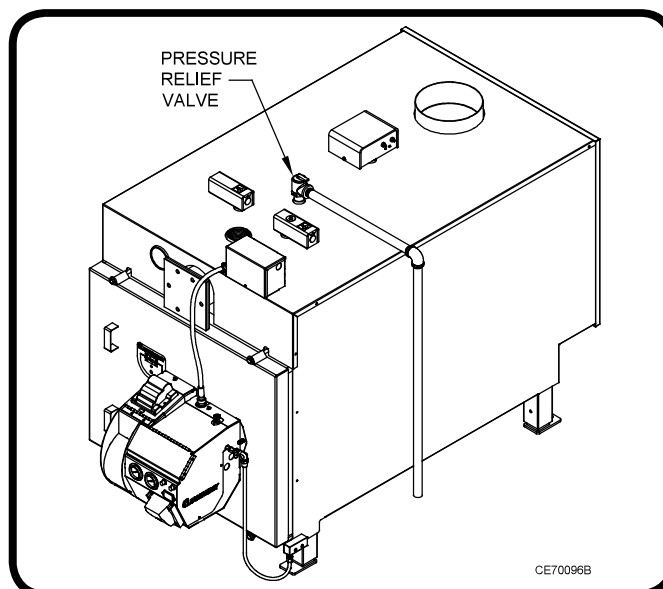
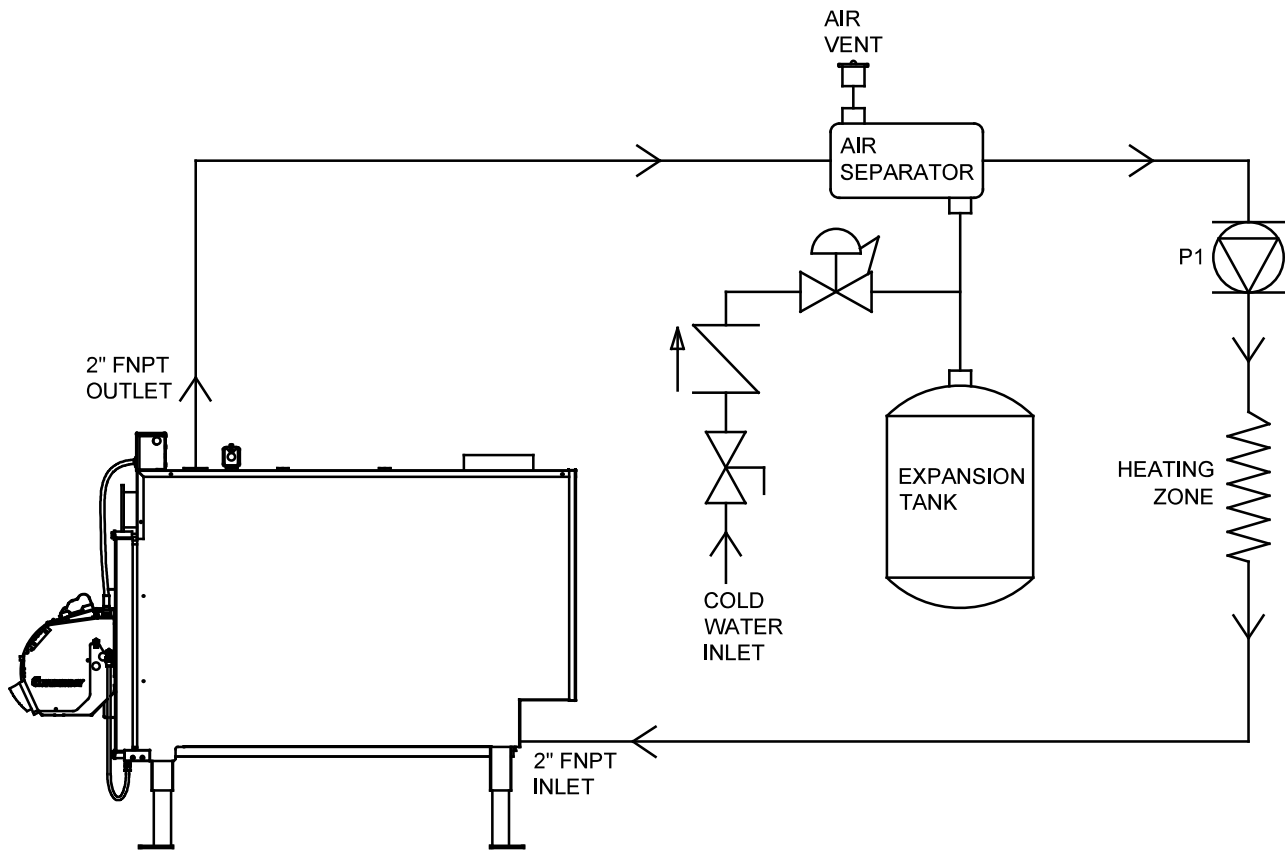
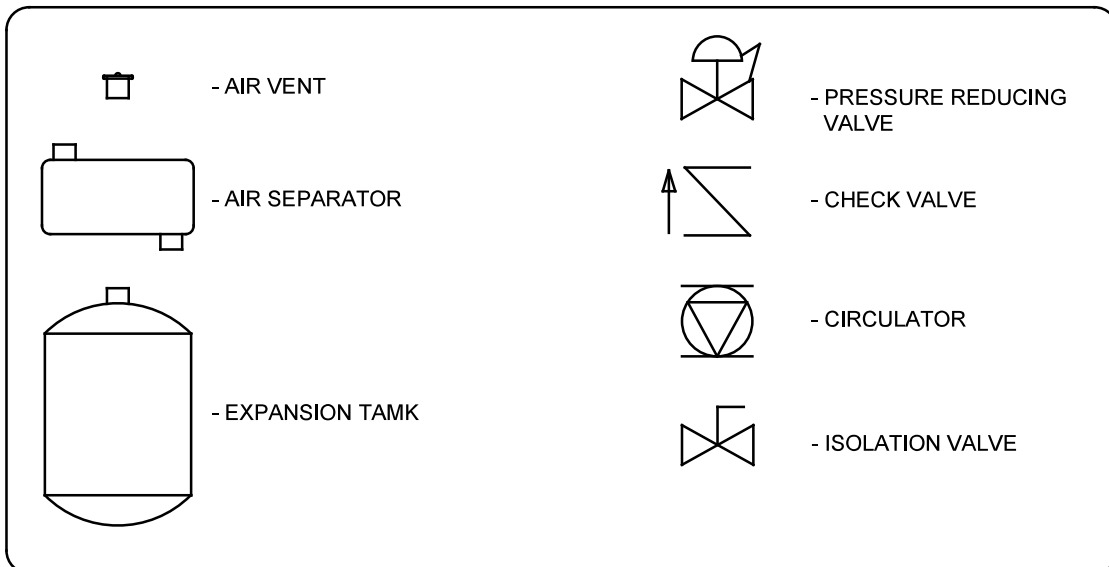

Figure 20: Installing the Pressure Relief

# BOILER INSTALLATION



## WATER FLOW SYMBOLS



CE70091B

Figure 21: Typical Single Zone Connections



# BOILER INSTALLATION

## Inspecting the Boiler Installation:

**NOTICE:** The boiler installation should be inspected by qualified personnel before it is operated to ensure all state and local codes are followed.



**CAUTION:** Omitting or deviating from installation instructions in this manual may create hazardous operating conditions and void your warranty.

- (1) Confirm all clearances from combustibles as well as clearances for service are followed.
- (2) Make sure the boiler control settings are correct for the application. Refer to page# 23 for Recommended Boiler Control Settings.
- (3) If the boiler is installed in a tight enclosed room, make sure there is enough make-up air for proper ventilation and combustion air (refer to figure 22).



**WARNING:** Failure to supply adequate combustion air to the boiler will create unsafe operating conditions.

- (4) After the system has run through a complete cycle, check all fittings for leaks.
- (5) Make sure the pressure relief valve and water feed system work properly.
- (6) Leave the Owner's Manual near the boiler for future reference.



**CAUTION:** If the boiler is unattended during extremely cold weather and there is a component failure or power outage, frozen plumbing and water damage may occur in a short time. Equip the system so that it senses low temperature and initiates an effective action. Contact your local heating contractor for assistance.

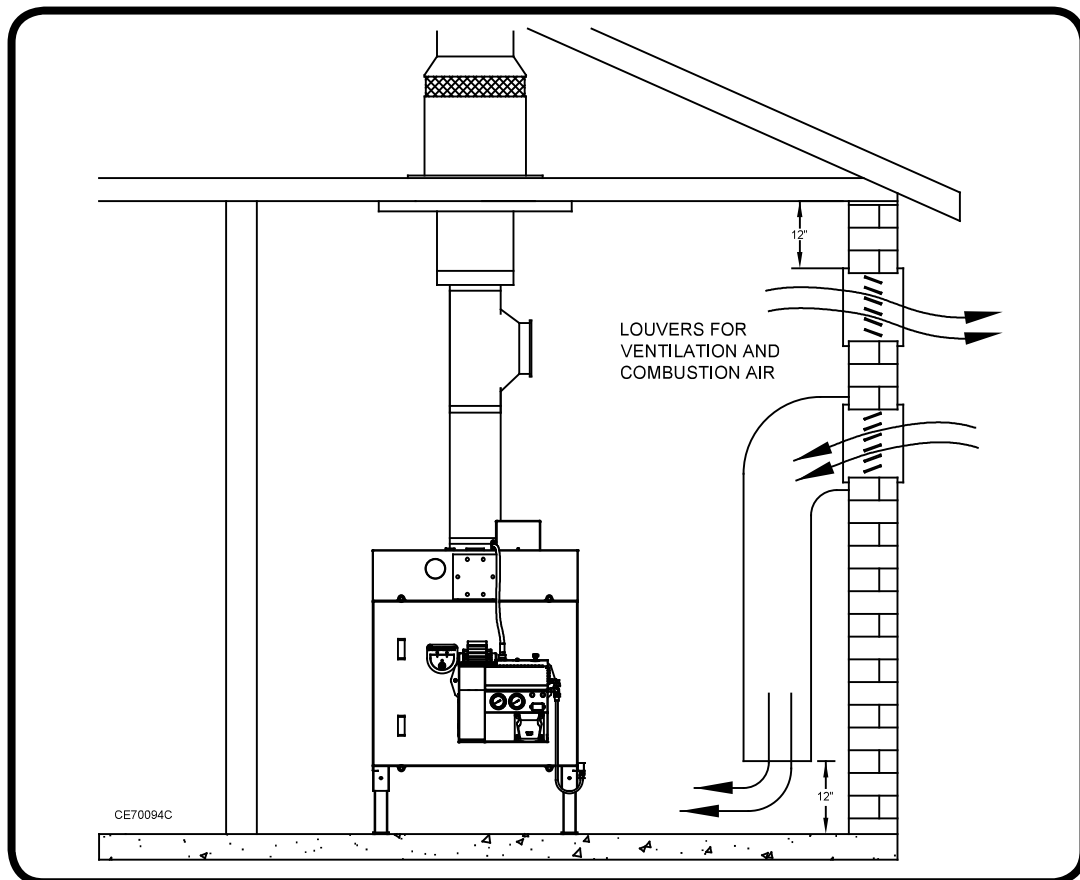

Figure 22: Louvers for Proper Ventilation and Combustion Air

# BOILER CONTROLS AND SAFETY COMPONENTS

## (1) Operating Aquastat

The Operating Aquastat shuts the burner off if the water temperature in the boiler reaches the water temperature set point. The Operating Aquastat will automatically reset when the water temperature drops to the required temperature.

## (2) Low Water Cut-Off

The Low Water Cut-Off shuts the burner off if the water level in the boiler goes below the Low Water Cut-Off sensor.

## (3) High Limit Aquastat (Red Manual Reset Button)

The High Limit Aquastat shuts the burner off if the water temperature in the boiler reaches the High Limit water temperature set point. The High Limit Aquastat must be manually reset if it functions.

## (4) Pressure Relief Valve

The Pressure Relief Valve will release excess pressure in the boiler (set at 30 psi).

NOTE: Install pipe from the pressure relief valve to within four inches of the floor to direct any release away from the boiler

## (5) Temperature / Pressure Gauge

This gauge is used to monitor the water temperature and pressure within the boiler.

## PREPARING THE METERING PUMP FOR START UP

- (1) Refer to Figure 23.
- (2) Remove the 1/2" NPT plug and open the ball valve on the inlet of the filter.
- (3) Pour oil into the inlet of the filter until the suction oil line, filter, and pump head are full.

**NOTICE:** A funnel can also be used to help direct the oil into the inlet of the filter.

- (4) Close the ball valve and insert the 1/2" NPT plug.
- (5) If the pressure oil line (from the pump to the boiler) is longer than 25 feet it is recommended to disconnect the oil line at the boiler and position a bucket under the line to catch the oil.

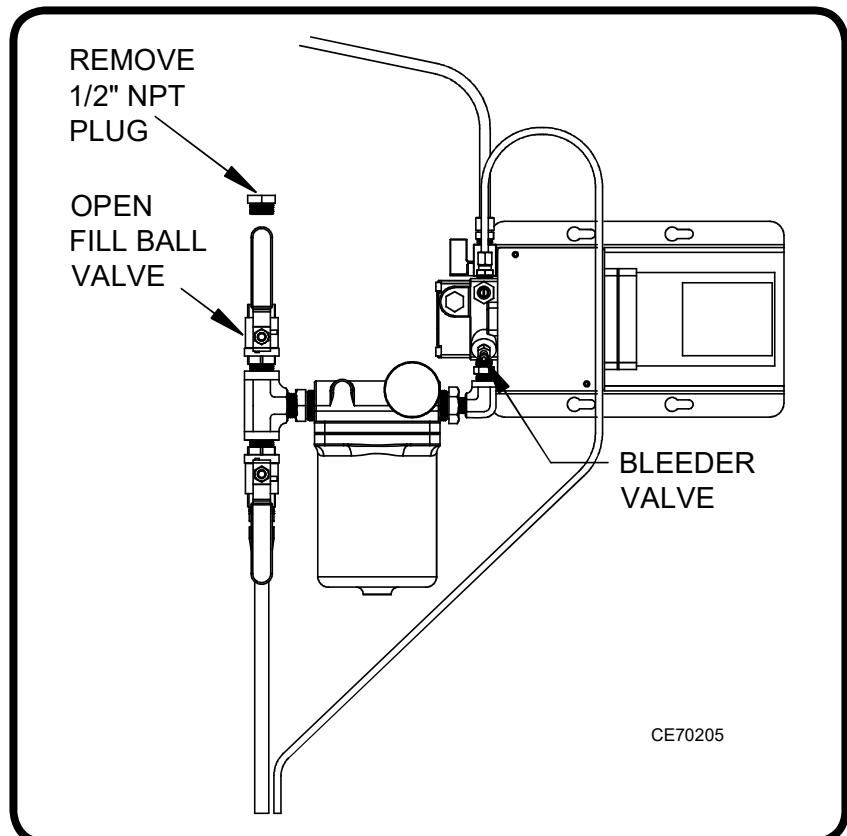

Figure 23: Priming the Metering Pump System

# STARTING AND ADJUSTING THE BURNER

## Preparing the burner for start up:

- (1) Plug the black cord into the top of the burner.
- (2) Turn on electrical power to the boiler.
- (3) Allow the burner heater element sufficient time to warm up the burner (time will vary according to ambient temperature). This usually takes 5 - 10 minutes. Once the burner has warmed up the “proving switch” will close and send power to the oil primary control.
- (4) Adjust the combustion air intake on the side of the burner to 7/8” (refer to Figure 24). This may be adjusted again once a flame is established.
- (5) Adjust the wall thermostat 10 - 20 °F above room temperature.
- (6) The burner should start when there is a call for heat. If the burner does not start, wait a few more minutes to ensure the burner is warmed up. If the burner still does not start try resetting the oil primary control (refer to the section on “Resetting the Oil Primary Control” in this manual).

## Priming the oil pump:



**CAUTION:** Failure to prime the pump properly can result in unstable combustion, puff back, and heavy smoke.

- (1) After the burner starts, press and hold the reset button for 15 seconds until the yellow light on the primary control turns on (the burner will shut off).
- (2) Release the reset button. The yellow light will turn off and the burner will start again.
- (3) Within 15 seconds click (push and release) the reset button. This will transition the primary control to “Pump Prime” mode which will bypass the flame sensor and keep the pump on for 4 minutes.
- (4) Open the pump bleeder valve and purge all air bubbles from the pump (refer to Figure 23).
- (5) After 4 minutes the yellow light on the primary control will turn off and the control will automatically return to standby mode.
- (6) Repeat steps 1 - 5 until the pump is fully primed and oil is delivered to the burner.

## Adjusting the burner:

- (1) Once a flame is established adjust the combustion air intake and the compressed air pressure to maintain a healthy flame (refer to Figure 24).
- (2) The air intake plate on the left side of the burner can be adjusted to increase or decrease the pie shaped opening sizes to let in more or less combustion air.
- (3) The compressed air pressure can be adjusted by turning the knob on the air regulator.
- (4) Visually inspect the flame to ensure proper settings.
- (5) The flame should go 1/2 to 3/4 of the way down the combustion chamber, and should not impinge on any surface of the combustion chamber.

# STARTING AND ADJUSTING THE BURNER

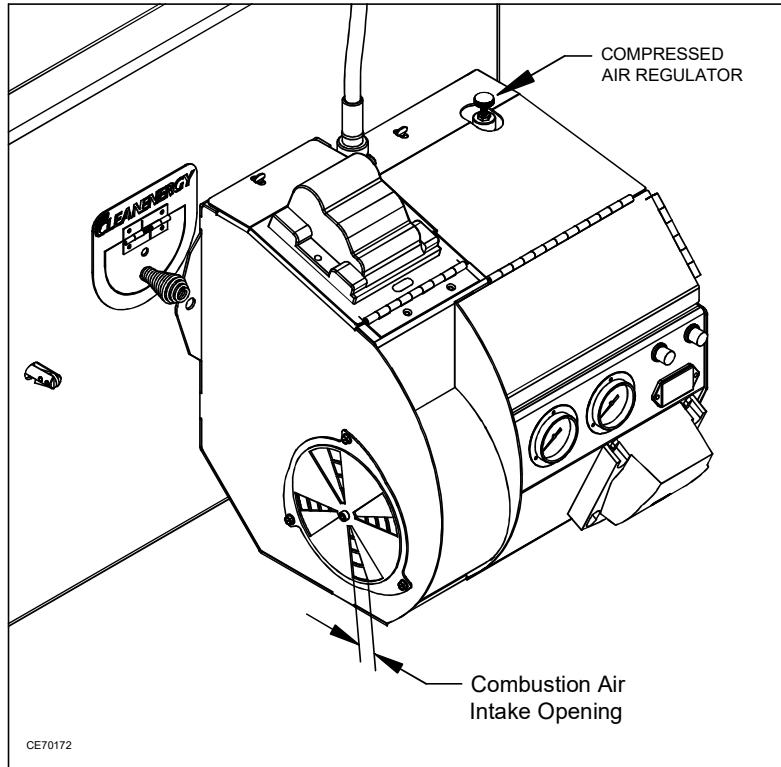

Each installation is unique. This measurement is for initial start-up only. Visually inspect the flame to make final adjustments for each installation.

| Model  | Combustion Air Intake Opening |
|--------|-------------------------------|
| CE 340 | 7/8"                          |

Figure 24: Flame Adjustment

## RESETTING THE OIL PRIMARY CONTROL



**WARNING:** Explosion and Fire Hazard. Failure to follow these instructions could result in heavy smoke emission, puff back, fire and smoke hazards.

- (1) Refer to Figure 25 to locate the oil primary control reset button.
- (2) Do not attempt to reset the burner if there is excess oil in the combustion chamber, vapor has accumulated in the unit, or when the boiler is hot.

**Oil flooded combustion chamber:** Turn off power to the boiler and disconnect the burner cord. Open the clean out door and wipe out the accumulated oil before continuing.

**Vapor filled combustion chamber:** Allow the unit to cool for 30 minutes and all vapors to dissipate before resetting the oil primary control.

- (3) When the combustion chamber has cooled, and there is no vapor or excess oil in the combustion chamber, push the reset button for 3 seconds and release.
- (4) If the burner does not restart contact the Clean Energy Heating Systems service department.

## RESETTING THE OIL PRIMARY CONTROL

Resetting the burner from restricted lock out:

**NOTICE:** If the control locks out three times before a call for heat is satisfied, it will enter restricted lockout mode in order to limit the amount of unburned oil in the combustion chamber.

- (1) Push the reset button in for 15 seconds. Release the reset button when the red light turns off and the yellow light turns on.

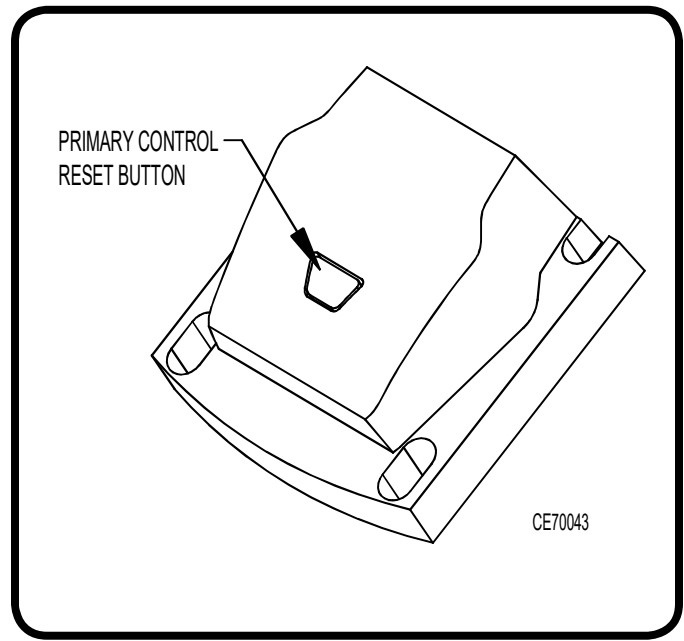

Figure 25: Oil Primary Control Reset Button

## SETTING THE DRAFT



**WARNING:** Do not operate you boiler if a proper draft is not obtained or damage to critical burner components will occur.

- (1) Allow the boiler to run for 5 to 10 minutes.
- (2) Refer to Figure 26 to locate the draft gauge hole.
- (3) Insert a draft gauge through the hole in the observation port. Follow the manufacturers instructions for adjusting the barometric damper to obtain  $-0.02''$  w.c. draft over fire.
- (4) If a proper draft is not obtained, follow the instructions below to check for a vacuum in your building.

Checking for vacuum in your building:

- (1) Have someone slowly open an overhead door while you are taking a draft reading.
- (2) Watch the draft gauge and tell them to stop when you get a  $-0.02''$  w.c. draft over fire.
- (3) Measure the opening created by the overhead door. This is the opening size you need for make up air to allow the boiler to draft properly.

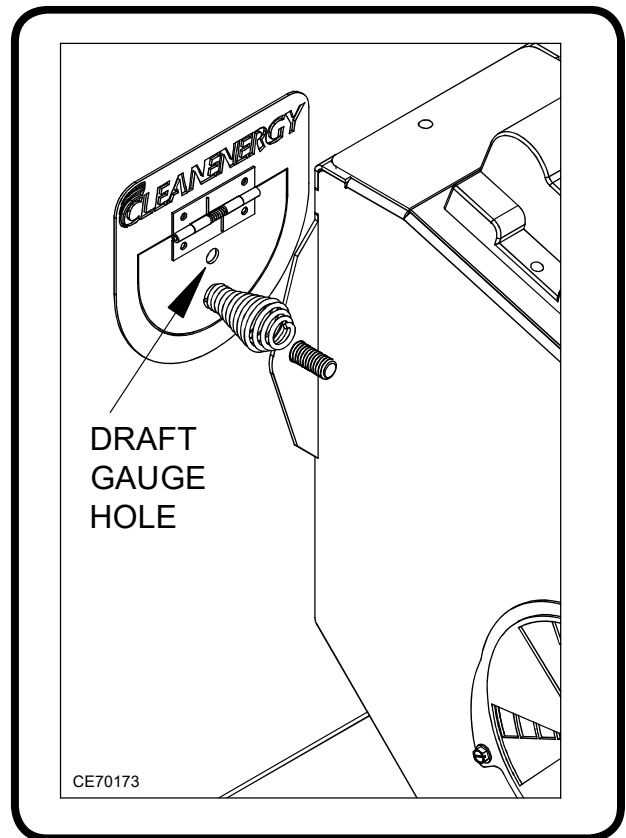

Figure 26: Draft Gauge Hole in the Observation Port

# MAINTENANCE

## Periodic Maintenance Schedule:

- (1) Clean the oil filter and pump head screen.....once a year
- (2) Clean sludge and water from the tank.....once a year
- (3) Clean ash from the heat exchanger.....800 hours
- (4) Flush the nozzle adapter heater block.....2000 to 3000 hours

## Cleaning the oil canister filter screen:

- (1) Place a container under the canister filter to catch any released oil.
- (2) Use a 3/16" allen wrench to loosen the canister.
- (3) Drop the canister down and remove the filter screen.
- (4) Thoroughly clean the filter screen in a parts washer.
- (5) Fill the canister 3/4 full with used oil (this will aid in pump priming) and slowly insert the filter screen back into the canister.
- (6) Tighten the 4 socket head screws in a crisscross pattern.

**NOTICE:** Do not over-tighten or the aluminum filter casting may crack.

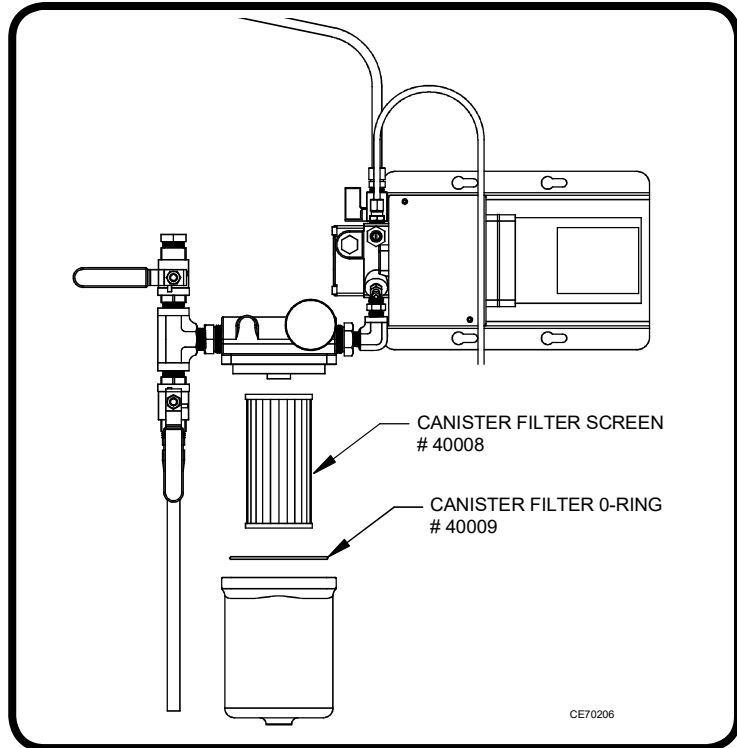

Figure 27: Removing the Oil Canister Filter Screen

## Cleaning the oil pump head screen:

- (1) Place a container under the oil pump head to catch any released oil.
- (2) Use a 5/32" allen wrench to loosen the pump head cover.
- (3) Remove the cover, pump head screen and gasket. Carefully scrape the gasket off if any pieces remain stuck to the pump head.
- (4) Thoroughly clean the pump head screen in a parts washer.
- (5) Install a new pump head gasket and put the cleaned screen in place.
- (6) Tighten the 4 socket head screws in a crisscross pattern.

**NOTICE:** Do not over tighten or the aluminum pump head cover may crack.

- (7) Once the filter and pump head screen are clean, follow instructions in the "Priming the Metering Pump" section.

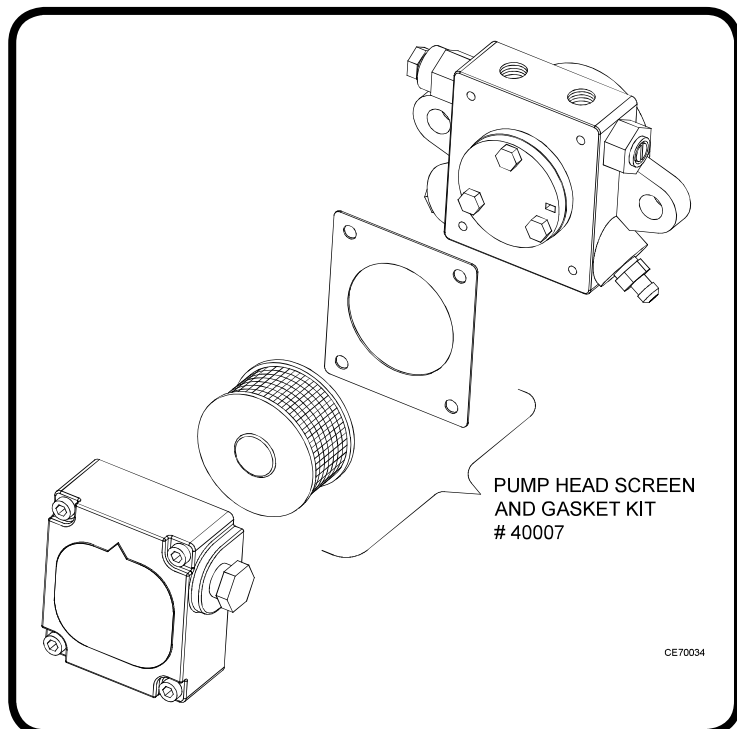

Figure 28: Removing the Oil Pump Head Screen

# MAINTENANCE

## Cleaning sludge and water from the bottom of the tank:

**NOTICE:** Because of the nature of used oil handling practices, it is very difficult to keep all water and sludge out of the used oil supply. Drain the used oil supply tank at least once a year to ensure no unwanted substance is being delivered to the boiler.

- (1) Connect a tube to the drain on the bottom of the tank and collect a sampling in a drain pan or bucket. Keep draining the tank until all water and sludge has been removed.
- (2) If there is no drain on your supply tank insert a transfer pump with the suction line inserted down to the bottom of the tank. Keep pumping out the tank until all sludge and water has been removed.

## Cleaning ash from the heat exchanger:



**CAUTION:** Wear safety goggles, gloves, long sleeves and a dust mask when cleaning ash from the boiler. The accumulated ash is in the form of a fine powder and may cause irritation.



**CAUTION:** DO NOT attempt to clean ash from a hot boiler. It is a burn hazard as well as a fire hazard when the hot ashes are disposed of.

- (1) Refer to Figure 29.
- (2) Turn OFF power to the boiler and disconnect the power cord from the top of the burner.
- (3) Remove the four (4) bolts from the front clean out door.
- (4) Carefully swing open the front clean out door.
- (5) Remove the combustion sleeve and support blocks.
- (6) Remove the back shrouding. Remove the six (6) nuts fastening the back clean out door.
- (7) Brush out the combustion chamber and use an industrial vacuum to clean out the remaining ash.
- (8) Use a 2-1/2" flue brush to completely remove ash from the flue tubes.
- (9) Remove the chimney if necessary. Make sure there is no obstruction in the chimney.
- (10) Fasten all clean out doors and chimney components.

NOTE: It is recommended to use Anti-sieze on the clean out door bolts to allow easy removal for future cleanings.

## Flush the nozzle adapter heater block:

- (1) Refer to Figure 30.
- (2) Open the igniter hinge cover on the burner.
- (3) Remove the electrode
- (4) Loosen the oil line swivel fitting with a 9/16" open end wrench.
- (5) Disconnect the air line by pushing on the release ring and pulling the tube out of the fitting.
- (6) Disconnect the quick disconnect electrical connector.
- (7) Disconnect the 3/16" copper tubing from the oil gauge.
- (8) Carefully remove the entire aluminum nozzle adapter heater block from the burner.
- (9) Remove all the components from the nozzle adapter heater block.
- (10) Remove all the plugs from the oil ports with a 5/32" allen wrench.
- (11) Clean the nozzle adapter heater block in a parts washer. A tube cleaning wire brush (rifle barrel cleaning brush) can be used to properly clean the oil ports.
- (12) Blow out all passages with a compressed air blowgun.
- (13) Put all the plugs and components back on the nozzle adapter heater block and re-install it in the burner.

# MAINTENANCE

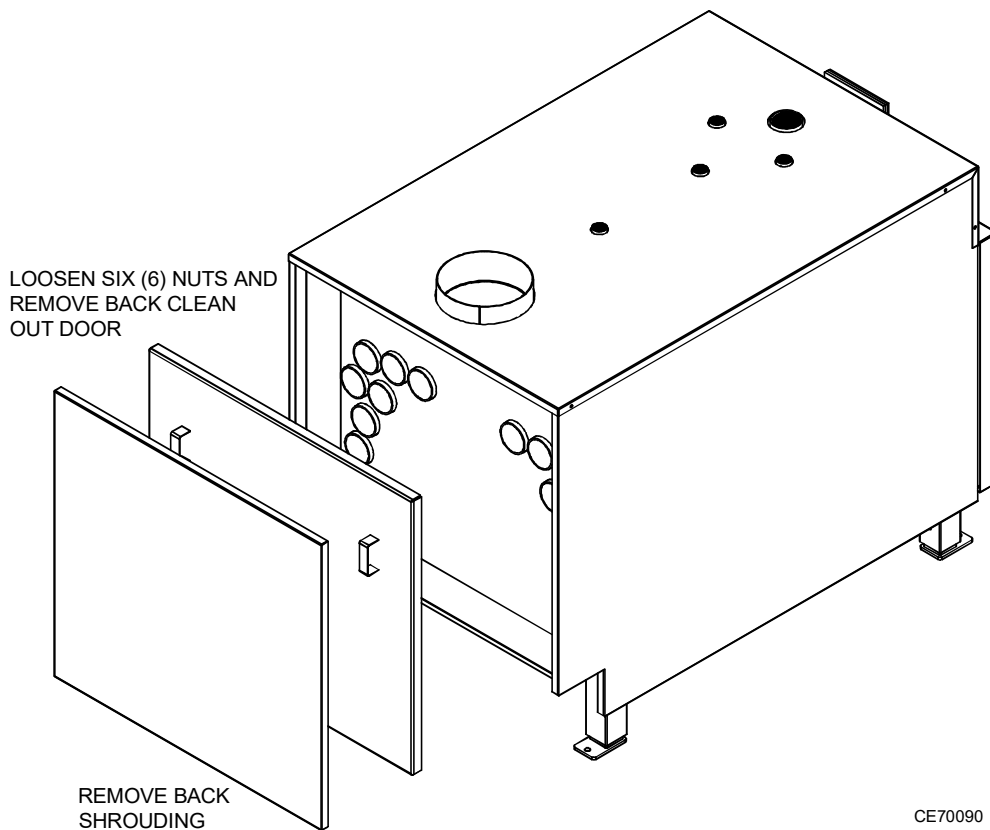
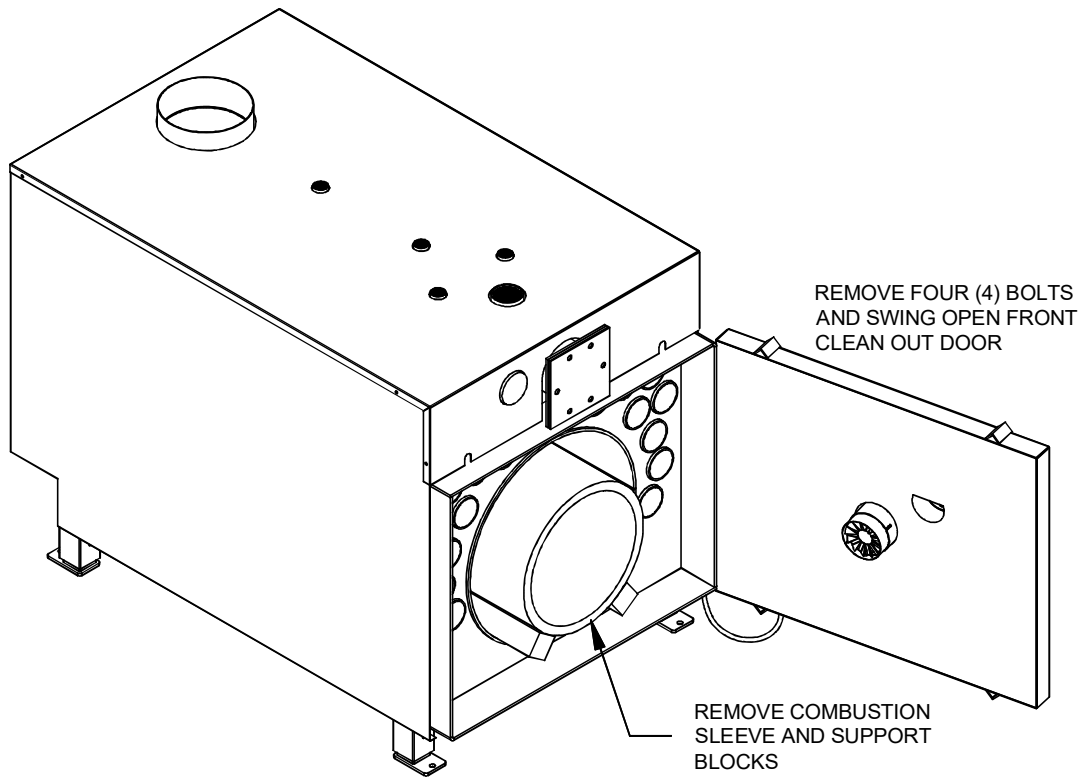
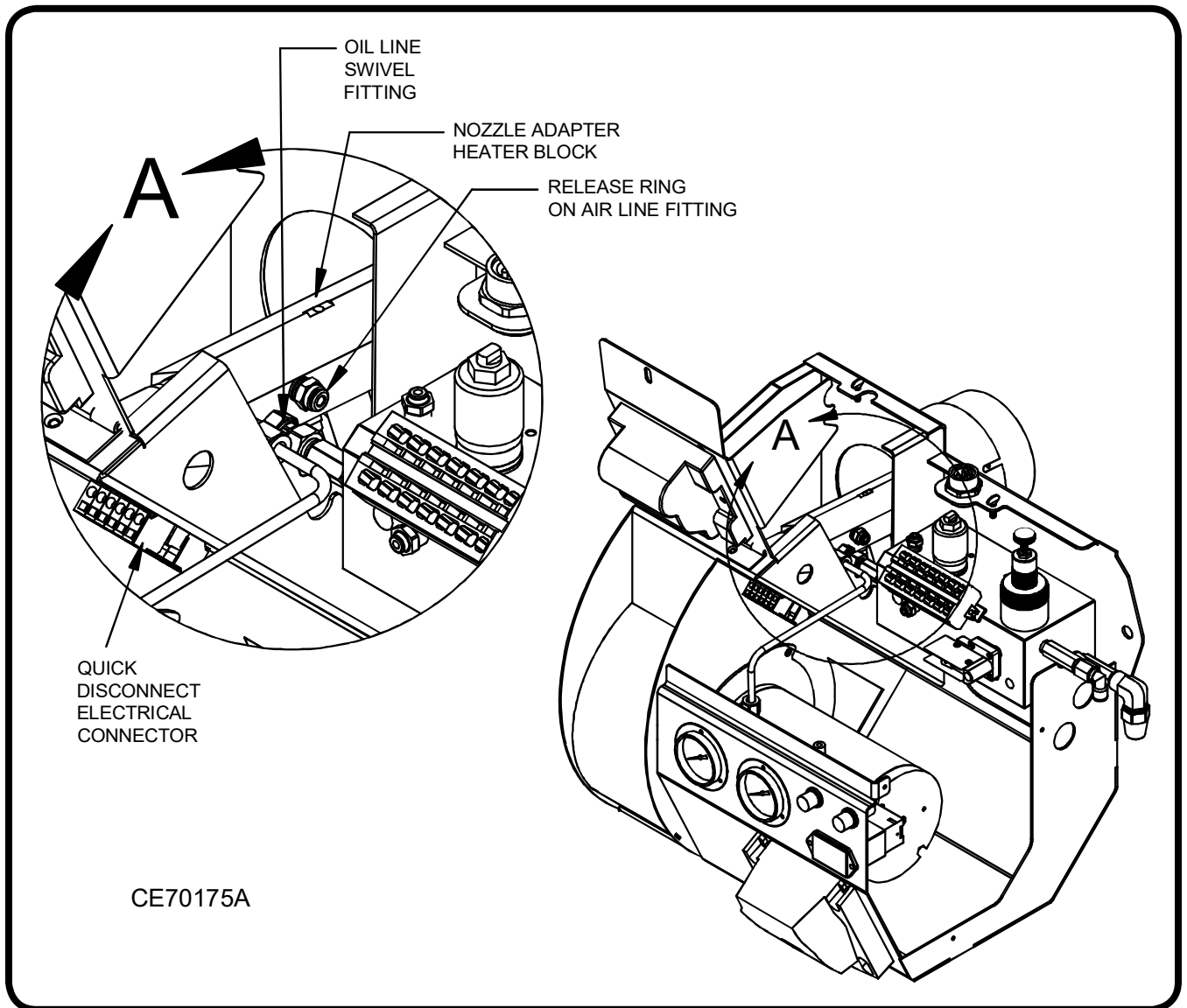

Figure 29: Cleaning Ash From the Heat Exchanger



# MAINTENANCE



Nozzle adapter heater block with all components and plugs removed.

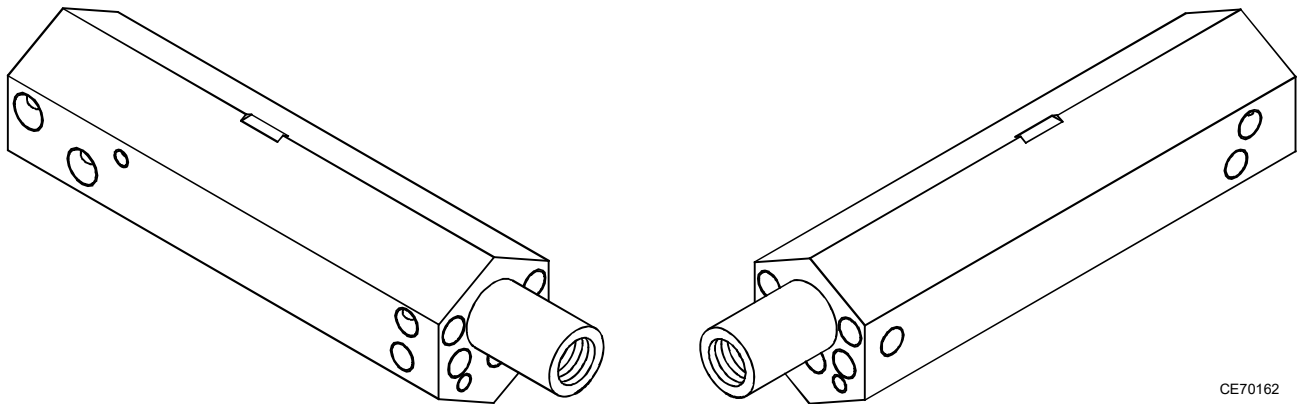
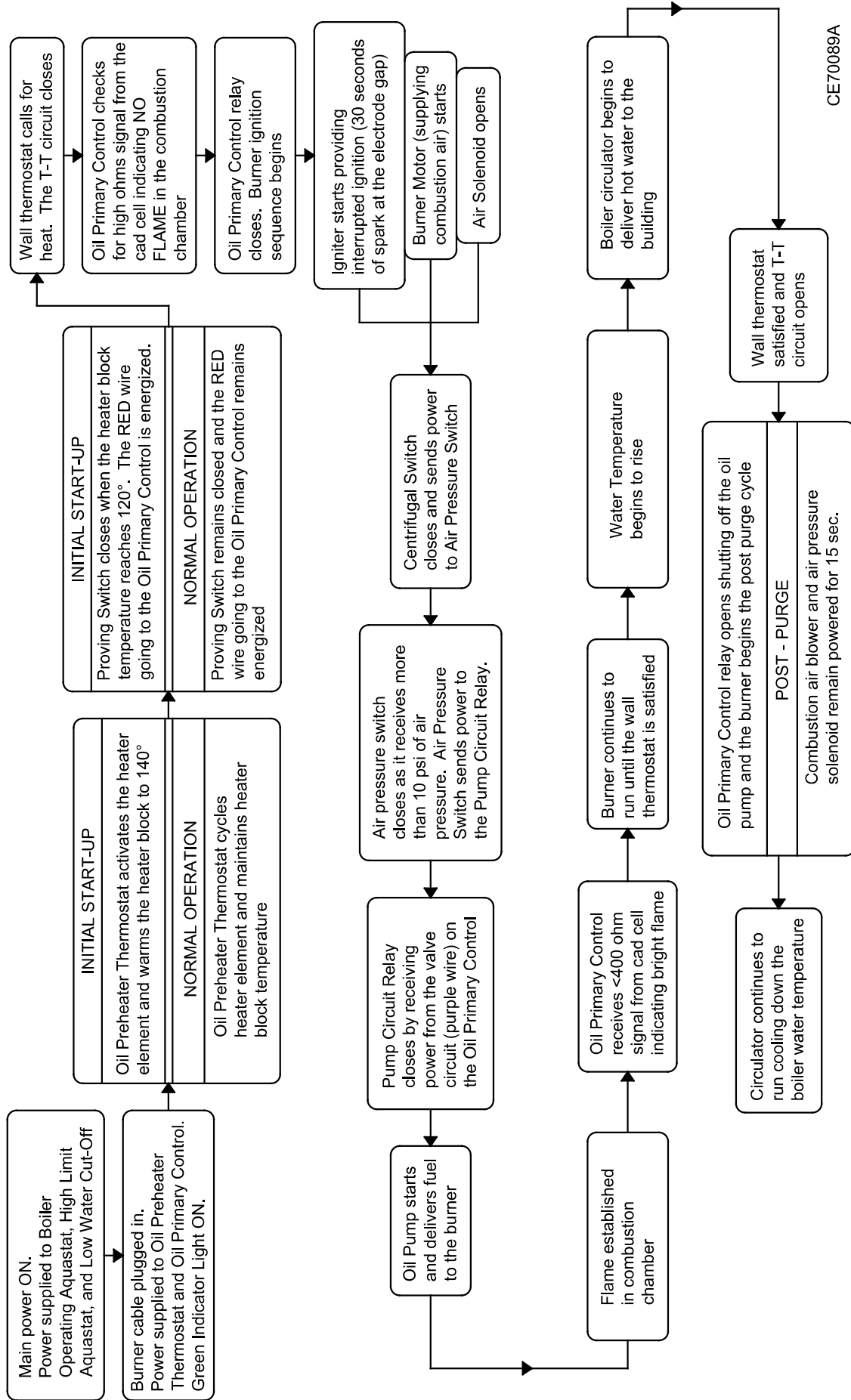

Figure 30: Flushing the Nozzle Adapter Heater Block

# BOILER SEQUENCE OF OPERATION



CE70089A

# BOILER DIMENSIONS

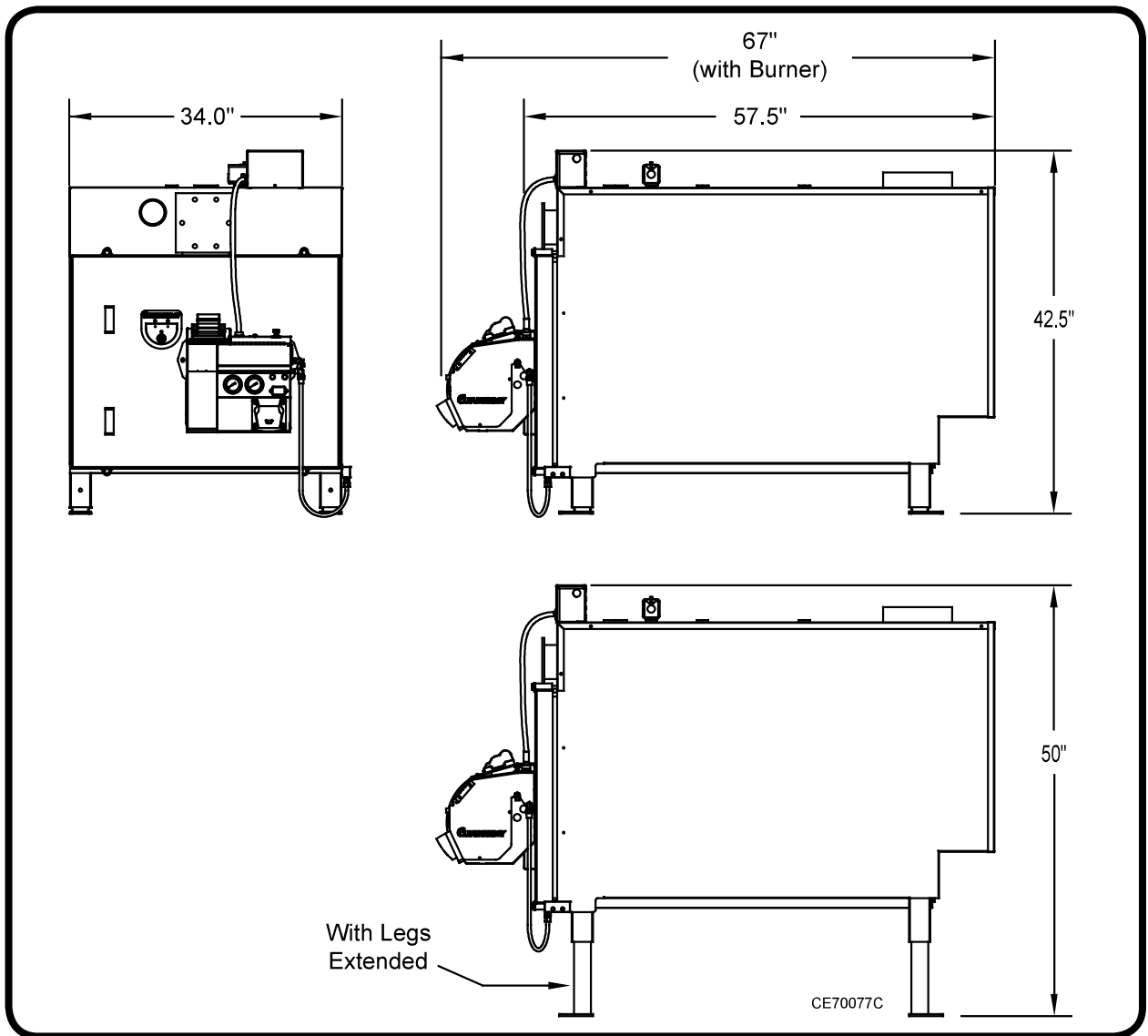

# WIRE DIAGRAMS

METERING PUMP GEARMOTOR WIRE DIAGRAM:

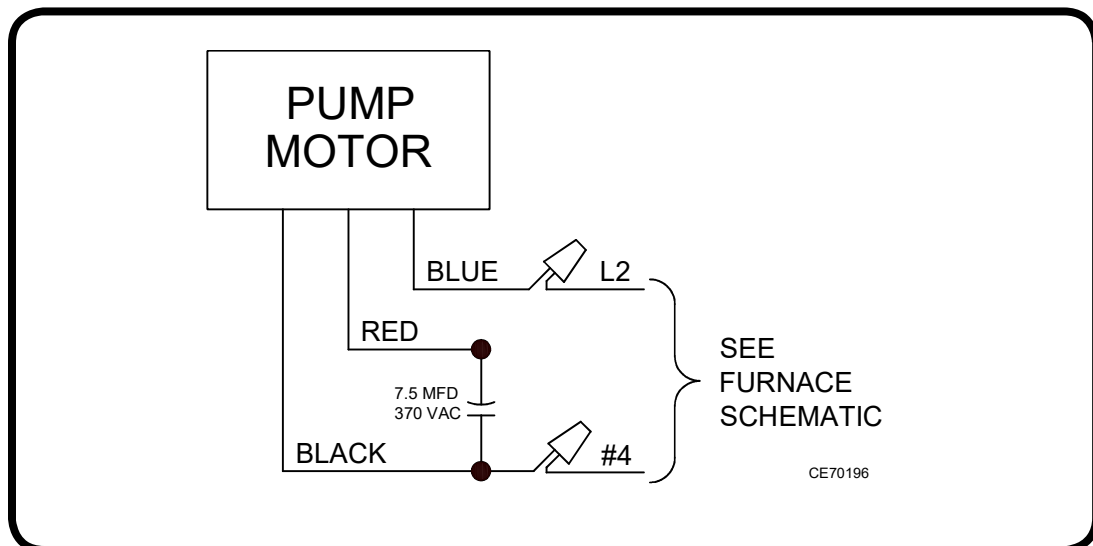

# WIRE DIAGRAMS

## CE-4 BURNER WIRE DIAGRAM:

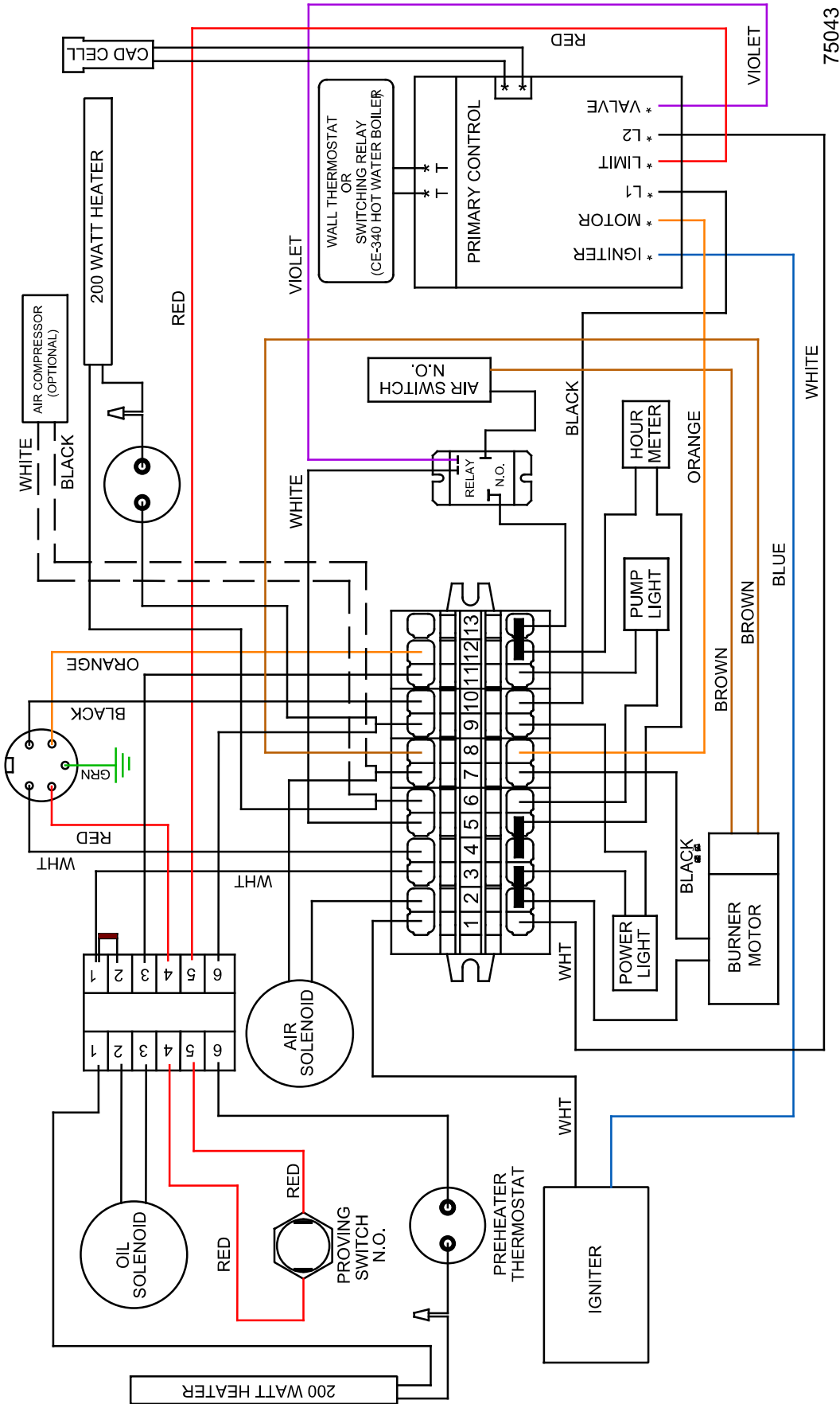

# WIRE DIAGRAMS

## CE-340 BOILER CABINET WIRE DIAGRAM:

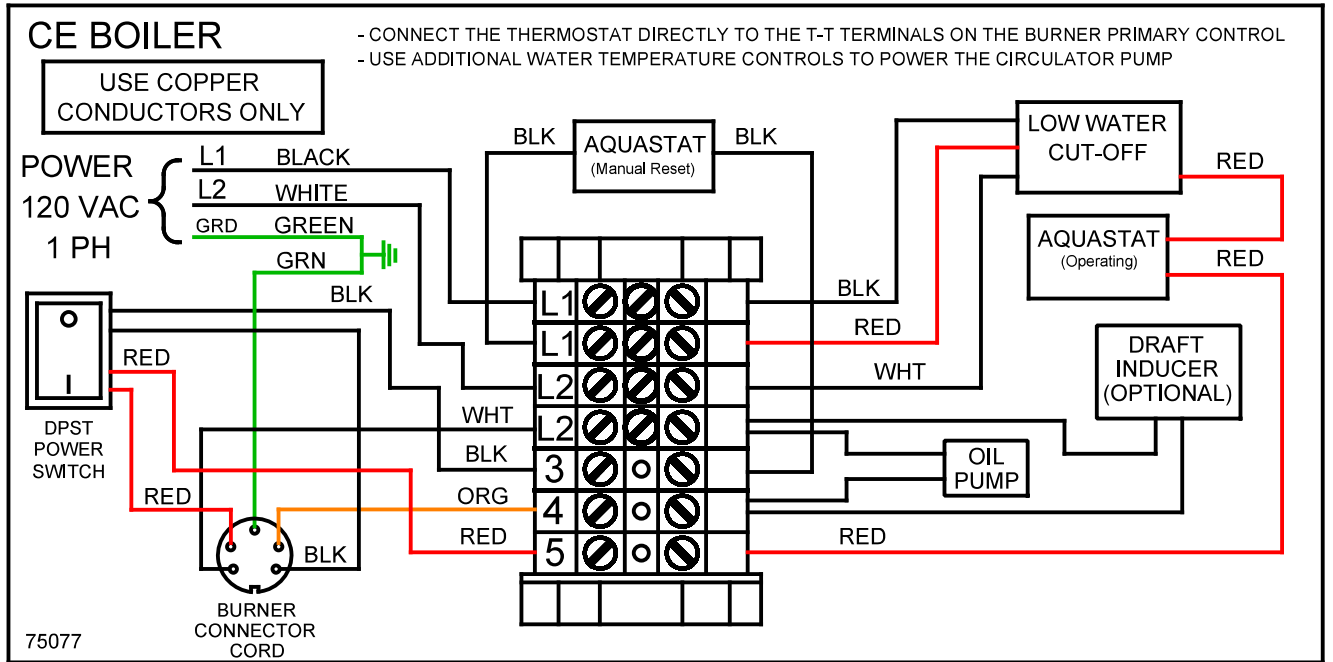

## BURNER POWER SWITCH

Review the figure below along with the Boiler Wire Diagram for additional information about the Burner Power Switch. Power to the burner must be shut off prior to disconnecting or connecting the Burner Power Cord.

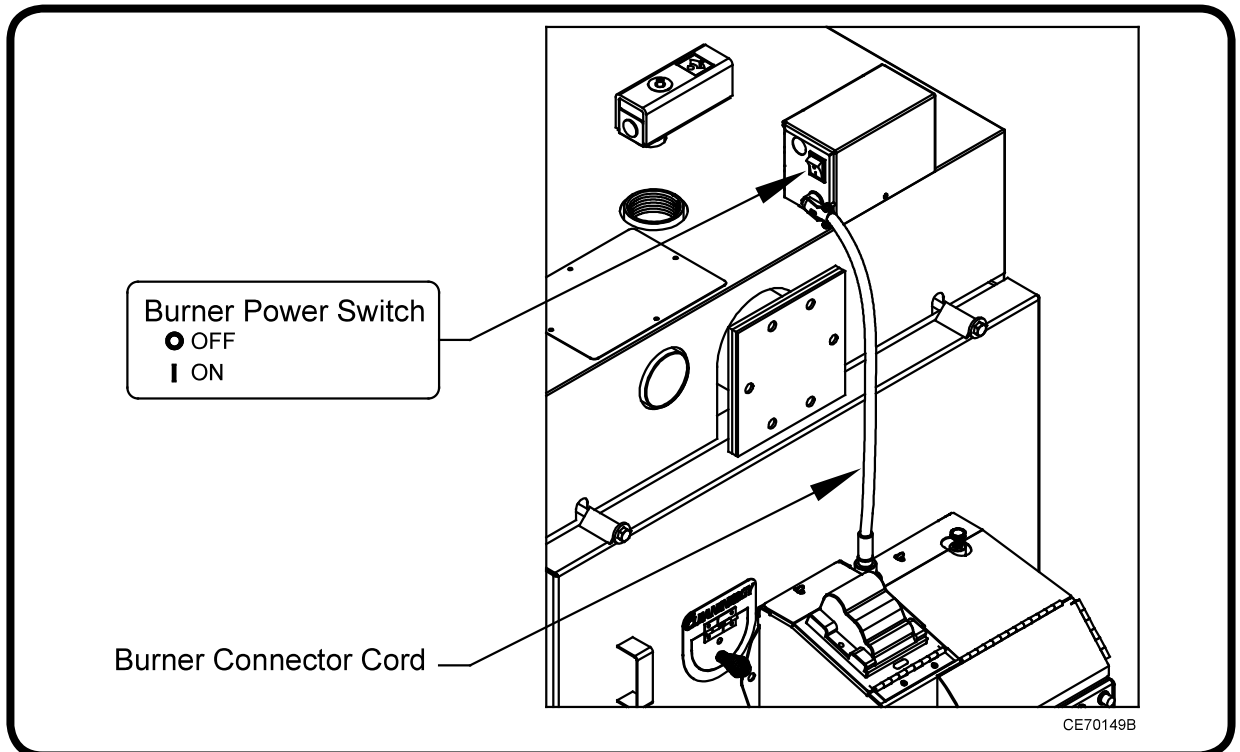

Burner Power Switch Location

# CE-3 / CE-4 BURNER ASSEMBLY

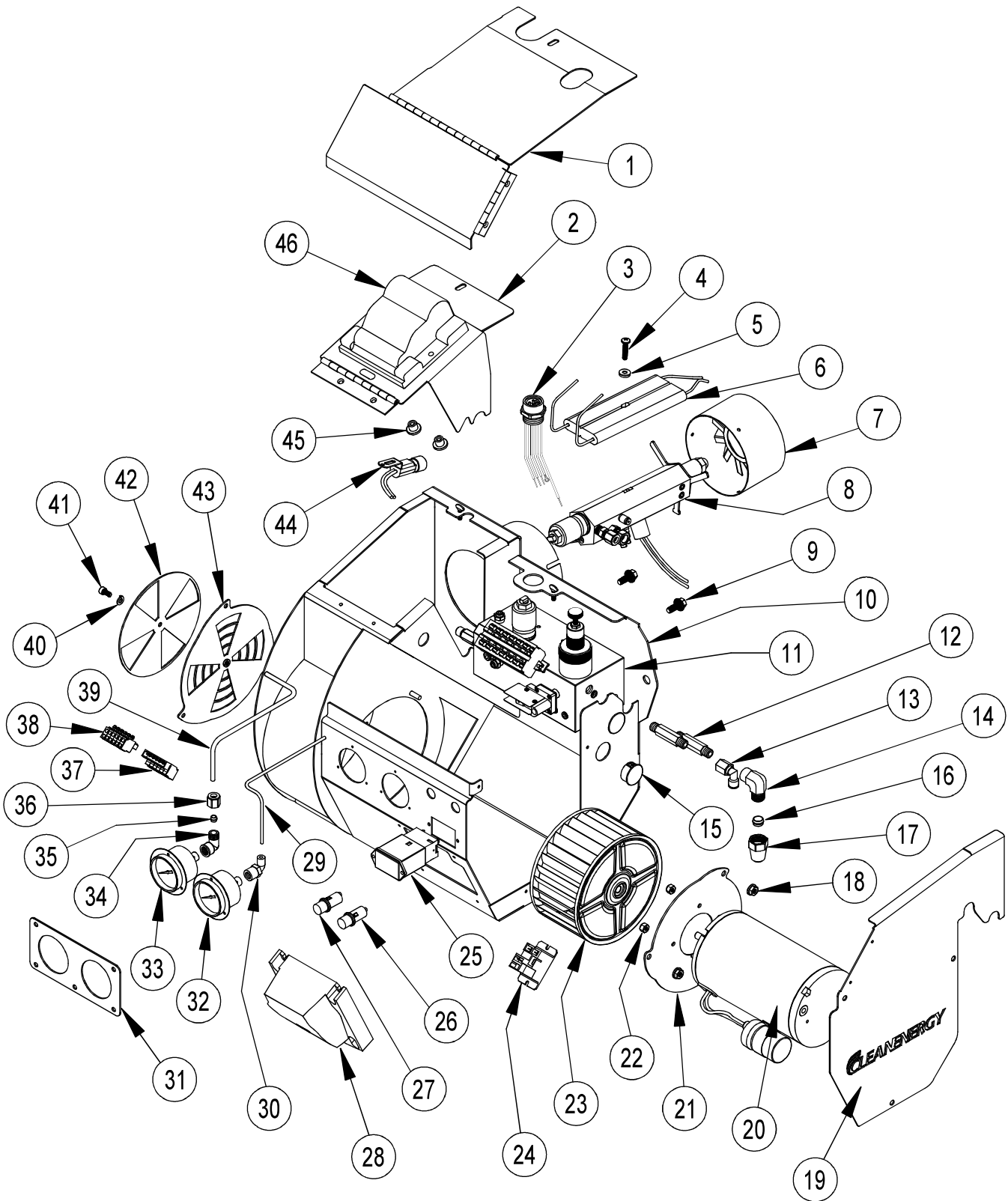

| ITEM | PART # | DESCRIPTION                              | QTY. |
|------|--------|--|------|
|      | 60301  | CE-3 EZ Burner Assembly                  |      |
|      | 60401  | CE-4 EZ Burner Assembly                  |      |
| 1    | 65030  | Burner Housing Top Cover                 | 1    |
| 2    | 65029  | Ignitor Hinge Plate                      | 1    |
| 3    | 30025  | Burner Receptacle (5-Wire)               | 1    |
| 4    | 58045  | Machine Screw 10-32 x 7/8                | 1    |
| 5    | 58040  | Washer Neoprene Bonded #10 - 1/2 OD      | 1    |
| 6    | 30001  | Electrode                                | 1    |
| 7    | 65041  | Retention Head                           | 1    |
| 8    | 60020  | Nozzle Adapter Heater Block Assembly     | 1    |
| 9    | 58014  | HHCS 1/4 - 20 x 1/2                      | 2    |
| 10   | 65028  | Burner Housing                           | 1    |
| 11   | 50008  | Burner Manifold Block                    | 1    |
| 12   | 50065  | 1/8 MP X 2 HEX NIPPLE                    | 2    |
| 13   | 50056  | 1/4 TUBE x 1/8 FNPT 90°                  | 1    |
| 14   | 50059  | 3/8 Compression x 1/8 FNPT 90°           | 1    |
| 15   | 30057  | Plug - push in 7/8" hole                 | 2    |
| 16   | 50051  | 3/8" Compression Ferrule                 | 1    |
| 17   | 50052  | 3/8" Compression Nut                     | 1    |
| 18   | 58023  | Flange Serrated Nut 10-24 Z              | 3    |
| 19   | 20236  | Right Side Cover                         | 1    |
| 20   | 30017  | Burner Blower Motor                      | 1    |
| 21   | 20034  | Motor Mount Plate                        | 1    |
| 22   | 58024  | Lock Nut 8-32 Nylon Z                    | 4    |
| 23   | 50015  | Squirrel Cage - Burner                   | 1    |
| 24   | 30009  | Relay SPST                               | 1    |
| 25   | 30016  | Hour Meter                               | 1    |
| 26   | 30033  | Green Light                              | 1    |
| 27   | 30034  | Amber Light                              | 1    |
| 28   | 50019  | Primary Control                          | 1    |
| 29   | 50085  | Tubing - Air Line (1/8" OD)              | 10"  |
| 30   | 50061  | 1/8 Tube - 1/8 FP x 90o                  | 1    |
| 31   | 20025  | Gauge Mount                              | 1    |
| 32   | 50017  | Air Pressure Gauge                       | 1    |
| 33   | 50016  | Oil Pressure Gauge                       | 1    |
| 34   | 50060  | 3/16 Compression x 1/8 FNPT 90°          | 1    |
| 35   | 50058  | 3/16 Compression Ferrule                 | 1    |
| 36   | 50057  | 3/16 Compression Nut                     | 1    |
| 37   | 30026  | Terminal Block Quick Disconnect - Male   | 1    |
| 38   | 30038  | Terminal Block Quick Disconnect - Female | 1    |
| 39   | 20153  | Copper Tube 3/16 oil gauge               | 1    |
| 40   | 58035  | Lock Washer #8                           | 1    |
| 41   | 58033  | Cap Screw Socket Head 10-24 x 3/8 SS     | 1    |
| 42   | 20037  | Air Intake - Outer Plate                 | 1    |
| 43   | 65006  | Air Intake - Inner Plate                 | 1    |
| 44   | 30022  | CAD CELL                                 | 1    |
| 45   | 30027  | Post Contact - Igniter                   | 2    |
| 46   | 50020  | Igniter                                  | 1    |

# NOZZLE ADAPTER / HEATER BLOCK ASSEMBLY

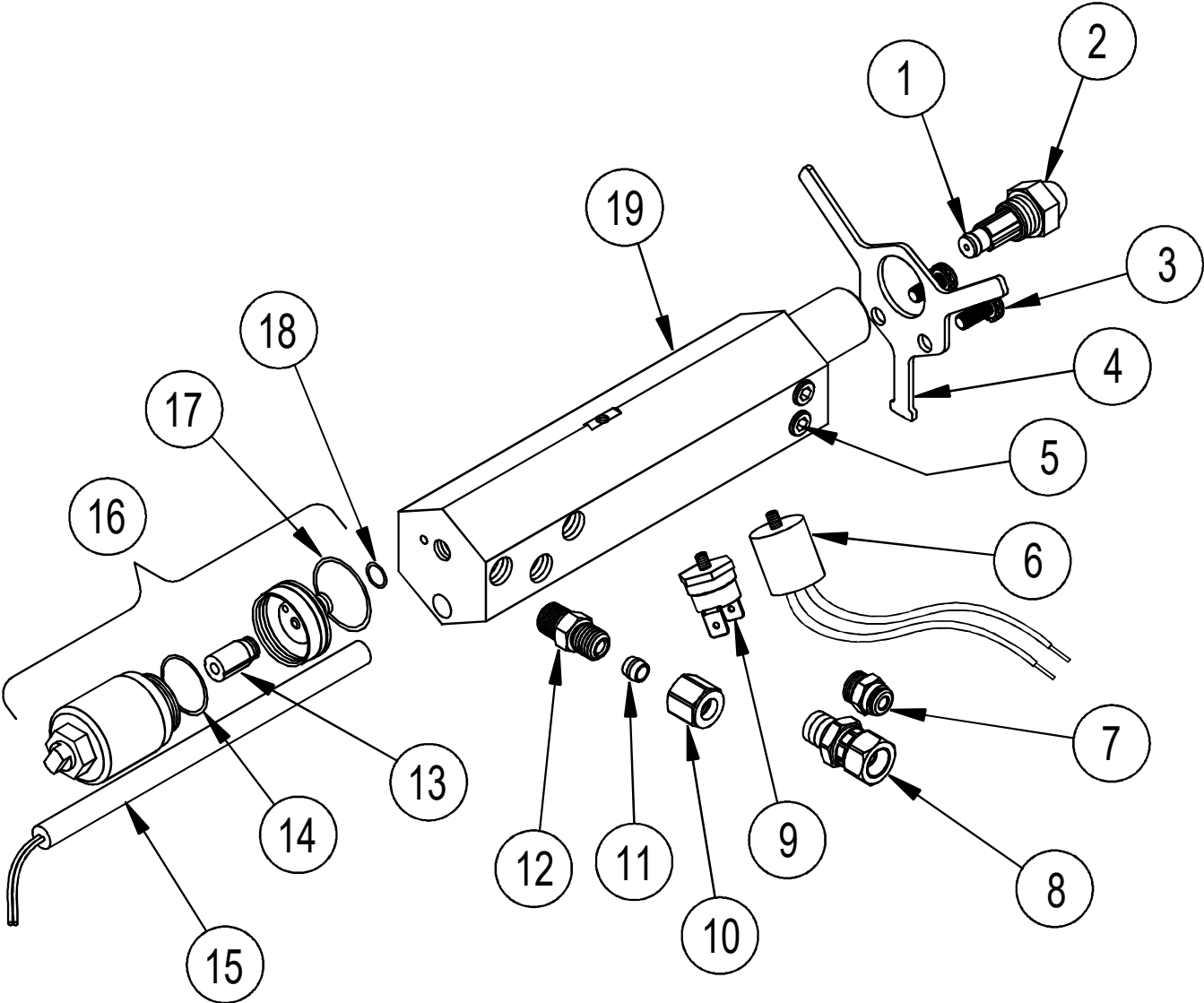



| ITEM | PART # | DESCRIPTION   | QTY. |
|------|--------|---|------|
|      | 60020  | Nozzle Adapter Heater Block Assembly                                  |      |
| 1    | 50250  | O-ring Nozzle   | 1    |
| 2    | 40005  | Nozzle 9-5 (Used in CE-3 EZ Burner on Model CE-140 / CE-180 / CE-250) | 1    |
| 2    | 40018  | Nozzle 9-8 (Used in CE-4 EZ Burner on Model CE-330 / CE-340 / CE-440) | 1    |
| 3    | 58054  | Machine Screw 10-32 x 3/8 Z Ext Tooth LW                              | 2    |
| 4    | 20008  | Nozzle Adaptor Bracket - Three Legs                                   | 1    |
| 5    | 50067  | Plug - Hex Socket   | 10   |
| 6    | 30011  | Thermostat 150F - Heater  | 1    |
| 7    | 50364  | Tube Fitting, 5/32 Tube X 1/8 MNPT                                    | 1    |
| 8    | 50024  | Swivel Fitting  | 1    |
| 9    | 30003  | Thermostat 120F - Proving Switch                                      | 1    |
| 10   | 50057  | 3/16 Compression Nut  | 1    |
| 11   | 50058  | 3/16 Compression Ferrule  | 1    |
| 12   | 50066  | 3/16 Compression x 1/8 MNPT   | 1    |
| 13   | 50256  | Plunger - Air/Oil Solenoid  | 1    |
| 14   | 50253  | O-Ring Solenoid Inner   | 1    |
| 15   | 30002  | Heat Element  | 1    |
| 16   | 50022  | Solenoid Air/Oil 115VAC   | 1    |
| 17   | 50255  | O-Ring Solenoid Large   | 1    |
| 18   | 50254  | O-Ring Solenoid Small   | 1    |
| 19   | 50009  | Nozzle Adapter / Heater Block   | 1    |

# MANIFOLD BLOCK ASSEMBLY

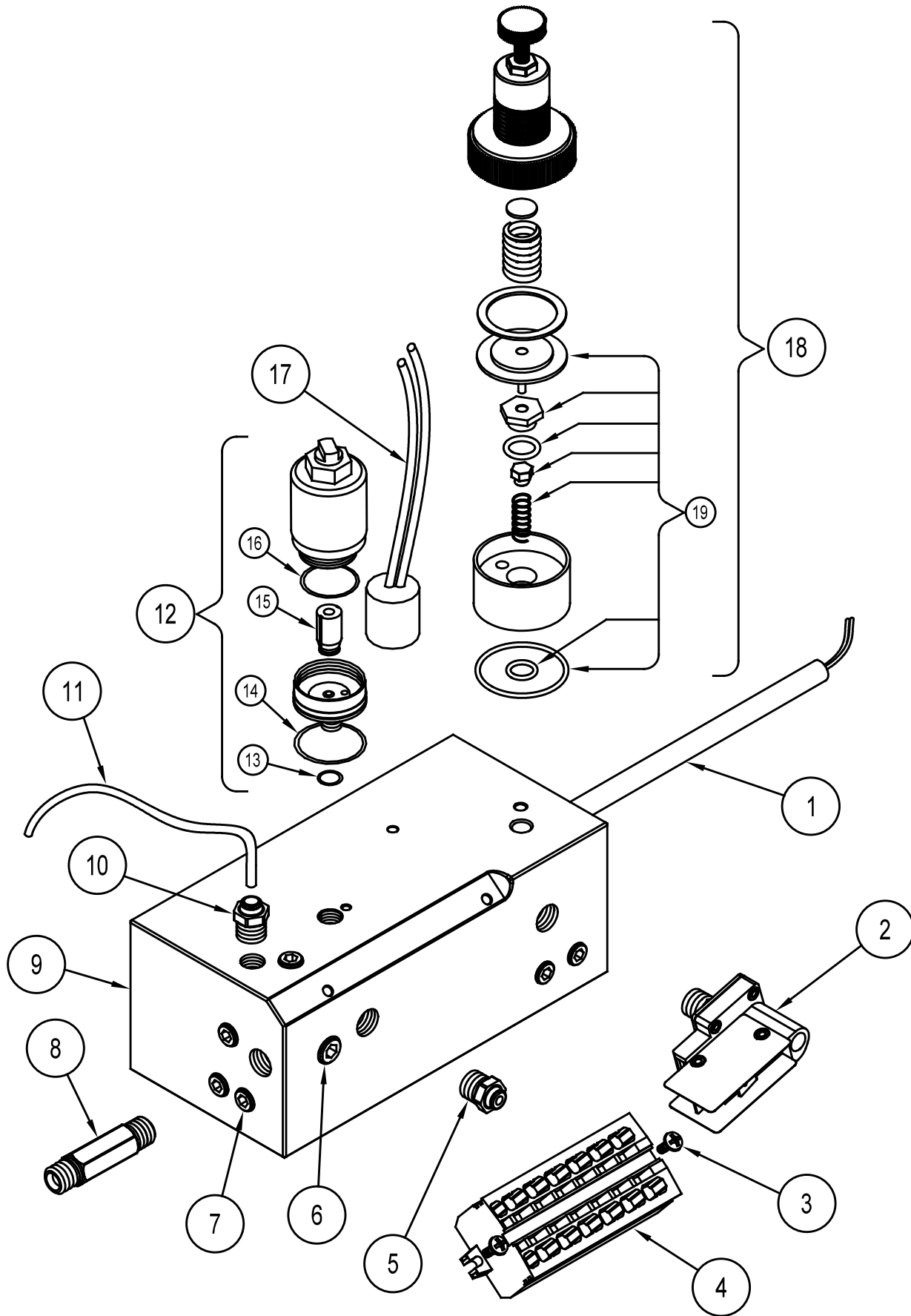

| ITEM | PART # | DESCRIPTION                            | QTY. |
|------|--------|--|------|
| 1    | 30002  | Heat Element                           | 1    |
| 2    | 50054  | Air Pressure Switch                    | 1    |
| 3    | 58029  | Machine Screw 8-32 x 3/8 Z             | 2    |
| 4    | 30010  | Terminal Block - Burner                | 1    |
| 5    | 50062  | Tube Fitting 1/8T x 1/8 MNPT           | 1    |
| 6    | 50188  | Plug - Hex Socket 1/8 NPT w/ Dry Seal  | 1    |
| 7    | 50067  | Plug - Hex Socket 1/16 NPT w/ Dry Seal | 11   |
| 8    | 50064  | 1/8 x 1-1/2 Nipple                     | 1    |
| 9    | 50008  | Burner Manifold Block                  | 1    |
| 10   | 50364  | Tube Fitting 5/32 Tube X 1/8 MNPT      | 1    |
| 11   | 50365  | Tubing - Air Line (5/32" OD) High Temp | 10"  |
| 12   | 50022  | Solenoid Air/Oil 115VAC                | 1    |
| 13   | 50254  | O-Ring Solenoid Small                  | 1    |
| 14   | 50255  | O-Ring Solenoid Large                  | 1    |
| 15   | 50256  | Plunger - Air/Oil Solenoid             | 1    |
| 16   | 50253  | O-Ring Solenoid Inner                  | 1    |
| 17   | 30011  | Thermostat 150F - Heater               | 1    |
| 18   | 50237  | Regulator - Manifold Mount (Screw-In)  | 1    |
| 19   | 50293  | Regulator Parts Kit (Screw-In)         | 1    |

\* Items 1 and 17 are used in the CE-4 EZ burner only on Model CE-330 / CE-340 / CE-440

# METERING PUMP ASSEMBLY

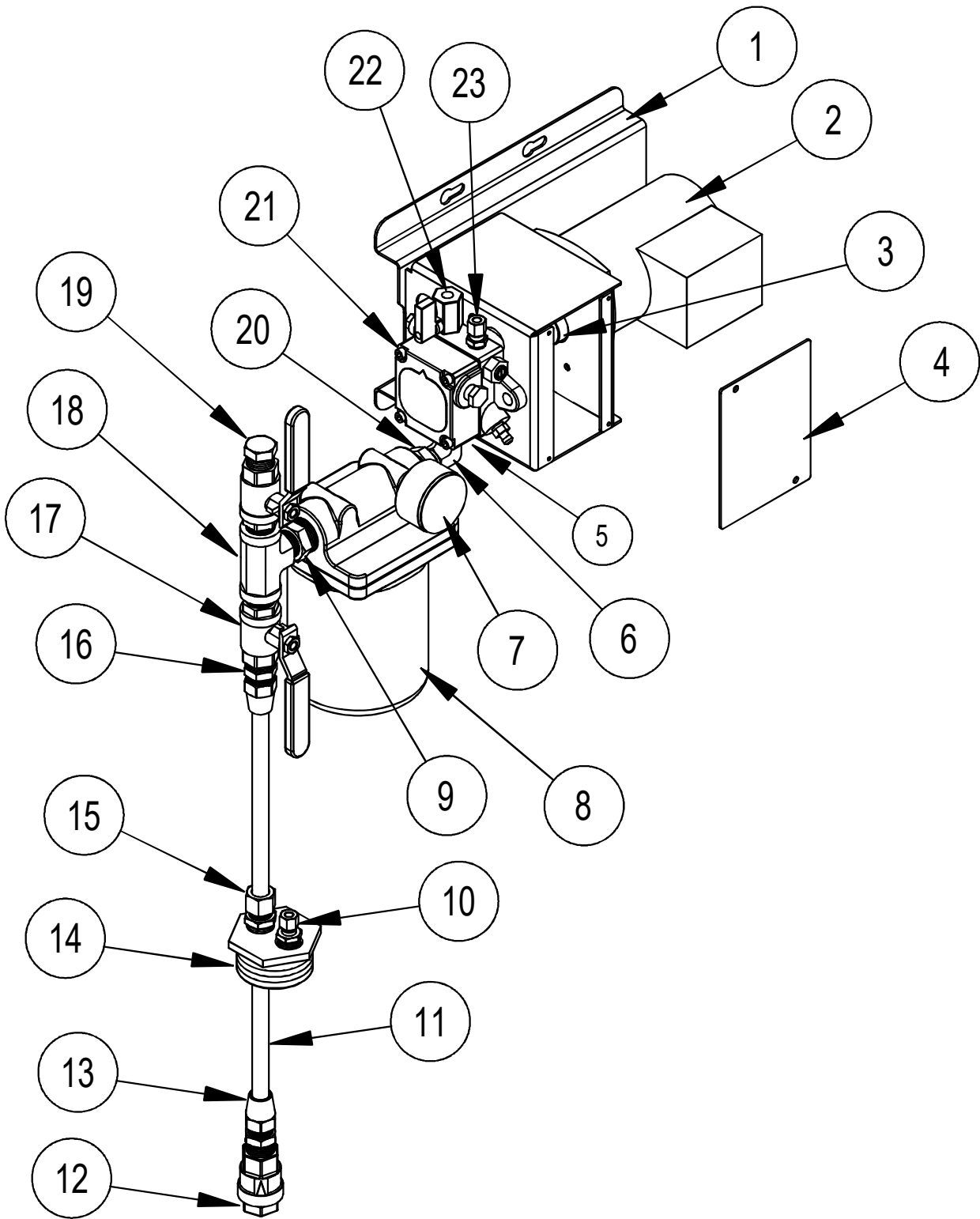

| Item | Part #        | Description                         | Qty. |
|------|---------------|-------------------------------------|------|
|      | 60081         | CE 140 Pump Assembly                |      |
|      | 60082         | CE 180 Pump Assembly                |      |
|      | 60083         | CE 250 Pump Assembly                |      |
|      | 60084         | CE 330 Pump Assembly                |      |
|      | 60085         | CE 340 Pump Assembly                |      |
| 1    | 65027         | Metering Pump Housing Assembly      | 1    |
| 2    | 50331         | Gearmotor - CE 140                  | 1    |
| 2    | 50332         | Gearmotor - CE 180                  | 1    |
| 2    | 50333         | Gearmotor - CE 250                  | 1    |
| 2    | 50334         | Gearmotor - CE 330                  | 1    |
| 2    | 50335         | Gearmotor - CE 340                  | 1    |
| 3    | 40019         | Metering Pump Coupling              | 1    |
| 4    | 20225         | Metering Pump Cover                 | 1    |
| 5    | 50028         | Nipple 1/4 NPT Hex Plated           | 1    |
| 6    | 50026         | ST EL 90° 1/4 F x 1/4 M             | 1    |
| 7    | 50006         | Gauge for Filter                    | 1    |
| 8    | 50005         | Filter                              | 1    |
| 9    | 50031         | Bushing 3/4 x 1/2 NPT               | 1    |
| 10   | 50036         | 1/2" MNPT x 1/4 Comp.               | 1    |
| 11   | USER SUPPLIED | 1/2" Copper Tubing                  |      |
| 12   | 50070         | Foot Valve 1/2"                     | 1    |
| 13   | 50034         | 1/2 Flare Nut 45°                   | 2    |
| 14   | 50044         | Duplex Fitting 2"                   | 1    |
| 15   | 50035         | Slip Through Fitting 1/2" MNPT      | 1    |
| 16   | 50033         | 1/2 Flare x 1/2 NPT Brass           | 2    |
| 17   | 50053         | Ball Valve 1/2 NPT                  | 2    |
| 18   | 50037         | Tee 1/2 F x 1/2 F x 1/2 M           | 1    |
| 19   | 50038         | Plug 1/2 NPT Hex                    | 1    |
| 20   | 50030         | Bushing 3/4 x 1/4 NPT               | 1    |
| 21   | 40014         | Metering Pump (A2RA-7720)           | 1    |
| 22   | 50238         | Ball Valve - Mini (1/8")            | 1    |
| 23   | 50241         | Straight Adapter 1/4" T x 1/8" MNPT | 1    |
|      | 40007         | Strainer and Gasket Kit (Pump Head) |      |
|      | 40008         | Screen Element (Lenz Filter)        |      |
|      | 40009         | O-Ring (Lenz Filter)                |      |

# CE-340 BOILER ASSEMBLY

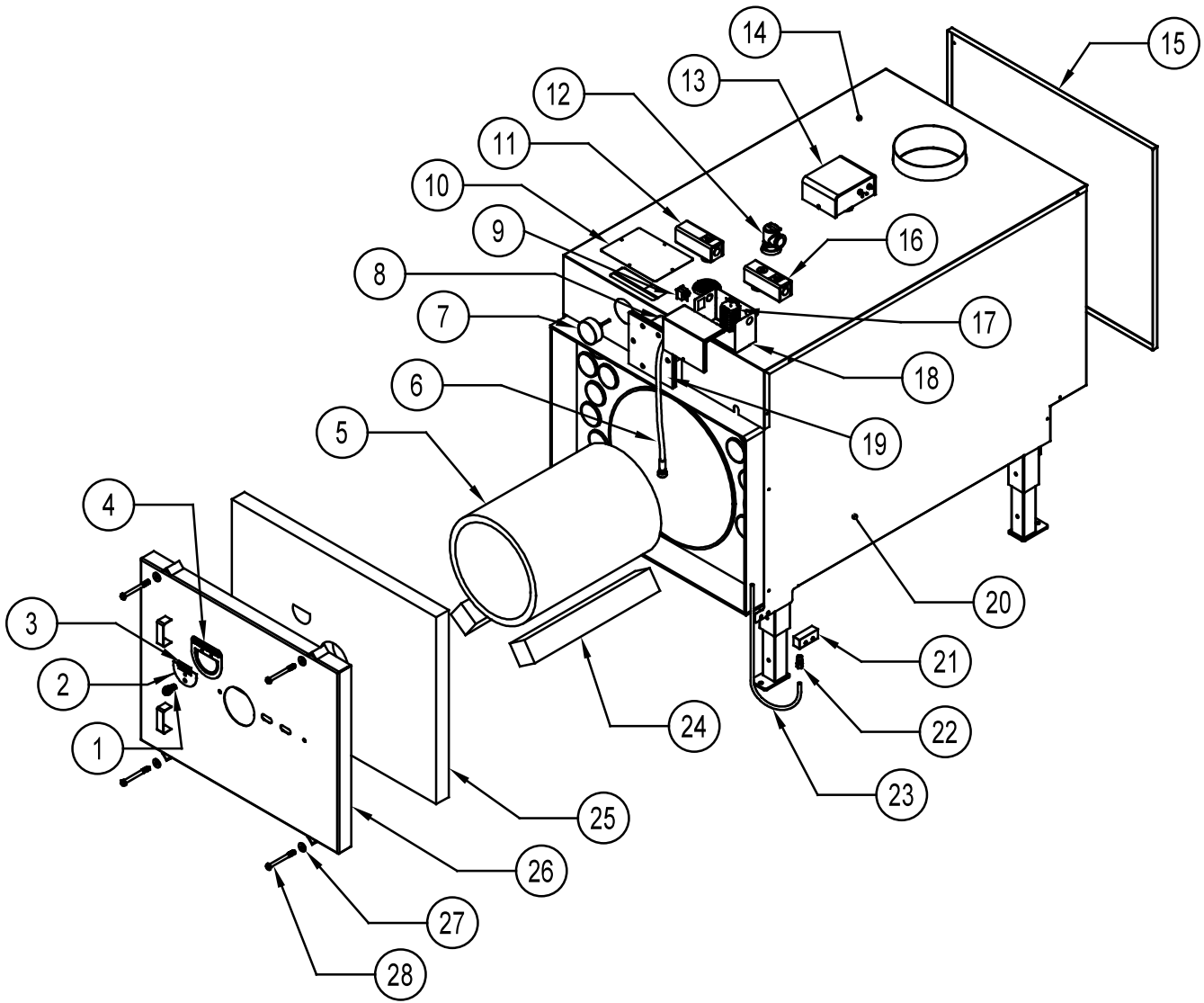

| ITEM | PART # | DESCRIPTION  | QTY. |
|------|--------|--|------|
|      | 10340  | CE 340 Boiler (w/ Burner and Pump)                 |      |
|      | 60340  | CE 340 Boiler Cabinet Only                         |      |
| 1    | 50079  | Spring Handle                                      | 1    |
| 2    | 20080  | Observation Port Lid                               | 1    |
| 3    | 50010  | Hinge - Observation Port                           | 1    |
| 4    | 20100  | Observation Port Ring                              | 1    |
| 5    | 50264  | Combustion Sleeve                                  | 1    |
| 6    | 30065  | Connector Cord - 5 Wire (CE-340 Boiler)            | 1    |
| 7    | 50189  | Gauge - Temp./Press. Boiler                        | 1    |
| 8    | 20217  | Electrical Box Lid                                 | 1    |
| 9    | 30072  | Burner Power Switch                                | 1    |
| 10   | 20086  | Cover - Shrouding                                  | 1    |
| 11   | 50193  | Aquastat - Operating                               | 1    |
| 12   | 50197  | Relief Valve - Boiler                              | 1    |
| 13   | 50194  | Low Water Cut-Off                                  | 1    |
| 14   | 20185  | Top - Boiler Shrouding                             | 1    |
| 15   | 20186  | Back Boiler Shrouding                              | 1    |
| 16   | 50192  | HL Aquastat - Manual Reset                         | 1    |
| 17   | 30023  | Terminal Block                                     | 1    |
| 18   | 20216  | Electrical Box                                     | 1    |
| 19   | 50198  | Domestic Hot Water Coil (Optional)                 | 1    |
| 20   | 20183  | Right Side - Boiler Shrouding                      | 1    |
| 21   | 50007  | Connector Block - Oil                              | 1    |
| 22   | 50042  | Swivel 3/8 Comp 1/4 NPT                            | 1    |
| 23   | 20182  | Hookup Tube (CE-340 Boiler)                        | 1    |
| 24   | 50190  | Combustion Sleeve Feet                             | 2    |
| 25   | 50201  | Insulation CE-340 Boiler Front Door                | 1    |
| 26   | 85055  | Front Door - CE 340 Boiler                         | 1    |
| 27   | 58067  | Washer - 1/2" Screw Size                           | 4    |
| 28   | 58066  | HHCS 1/2 - 13 X 6                                  | 4    |
|      | 20184  | Left Side - Boiler Shrouding                       | 1    |
|      | 50217  | Insulation CE-340 Boiler Front Header Side         | 2    |
|      | 50218  | Insulation CE-340 Boiler Front Header Top / Bottom | 2    |

Through the Wall Chimney Installation:

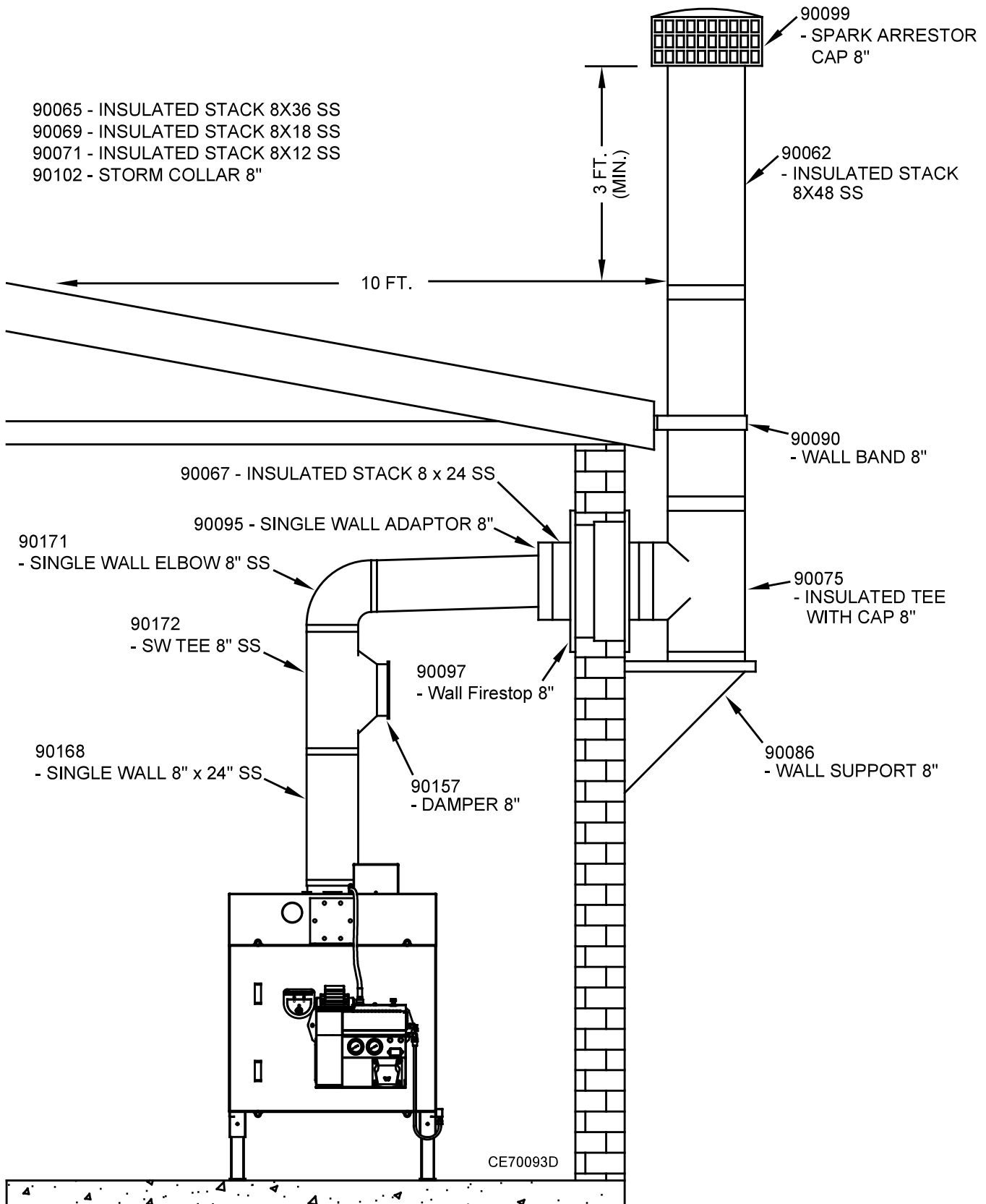



Through the Roof Chimney Installation:

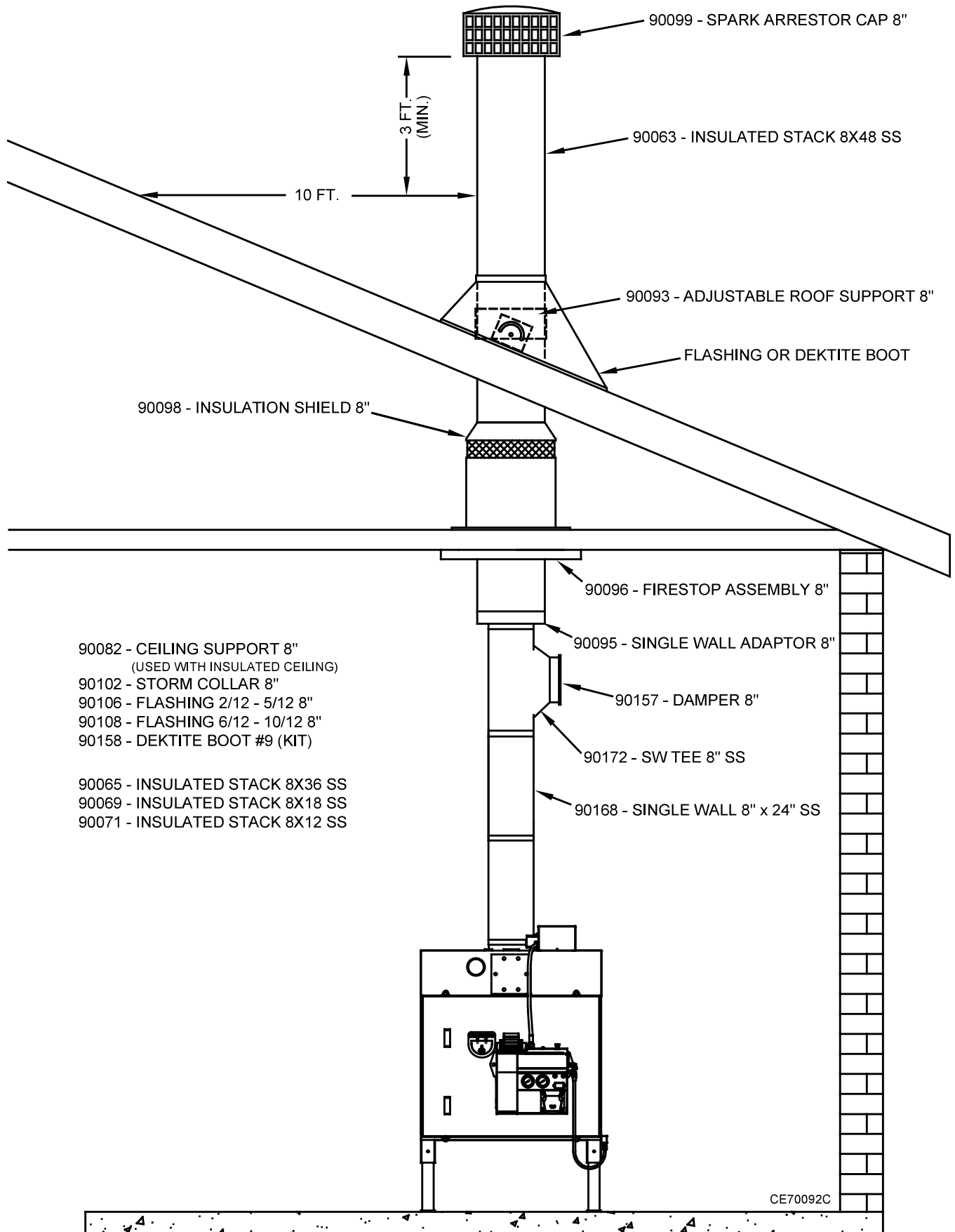

# SERVICE RECORDS

|                                       |                    |
|---------------------------------------|--------------------|
| CLEAN THE OIL CANISTER FILTER         | ONCE PER YEAR      |
| CLEAN THE PUMP HEAD SCREEN            | ONCE PER YEAR      |
| CLEAN ASH FROM THE HEAT EXCHANGER     | 800 HOURS          |
| CLEAN THE NOZZLE ADAPTER HEATER BLOCK | 2000 TO 3000 HOURS |

| HOURS | CLEAN OIL CANISTER FILTER | CLEAN PUMP HEAD SCREEN | CLEAN ASH FROM THE HEAT EXCHANGER | DRAIN OIL STORAGE TANK | CLEAN THE NOZZLE ADAPTER HEATER BLOCK |
|-------|---------------------------|------------------------|-----------------------------------|------------------------|---------------------------------------|
|       |                           |                        |                                   |                        |                                       |
|       |                           |                        |                                   |                        |                                       |
|       |                           |                        |                                   |                        |                                       |
|       |                           |                        |                                   |                        |                                       |
|       |                           |                        |                                   |                        |                                       |
|       |                           |                        |                                   |                        |                                       |
|       |                           |                        |                                   |                        |                                       |
|       |                           |                        |                                   |                        |                                       |
|       |                           |                        |                                   |                        |                                       |
|       |                           |                        |                                   |                        |                                       |
|       |                           |                        |                                   |                        |                                       |
|       |                           |                        |                                   |                        |                                       |
|       |                           |                        |                                   |                        |                                       |
|       |                           |                        |                                   |                        |                                       |
|       |                           |                        |                                   |                        |                                       |
|       |                           |                        |                                   |                        |                                       |
|       |                           |                        |                                   |                        |                                       |
|       |                           |                        |                                   |                        |                                       |
|       |                           |                        |                                   |                        |                                       |
|       |                           |                        |                                   |                        |                                       |
|       |                           |                        |                                   |                        |                                       |
|       |                           |                        |                                   |                        |                                       |
|       |                           |                        |                                   |                        |                                       |
|       |                           |                        |                                   |                        |                                       |
|       |                           |                        |                                   |                        |                                       |
|       |                           |                        |                                   |                        |                                       |
|       |                           |                        |                                   |                        |                                       |
|       |                           |                        |                                   |                        |                                       |
|       |                           |                        |                                   |                        |                                       |
|       |                           |                        |                                   |                        |                                       |
|       |                           |                        |                                   |                        |                                       |

# NOTES

## APPENDIX A

### Domestic Hot Water Coil Installation:



**DANGER:** Mixing valves must be used to supply domestic hot water at a safe temperature. Mixing valves are not intended to be the only scalding safe-guard.

- (1) Refer to Figure A2.
- (2) Remove the six nuts and bolts holding the cover in position.
- (3) Carefully slide the domestic hot water coil, with the rubber gasket in place, into the tube.
- (4) Tighten the hot water coil in position with the six nuts and bolts.

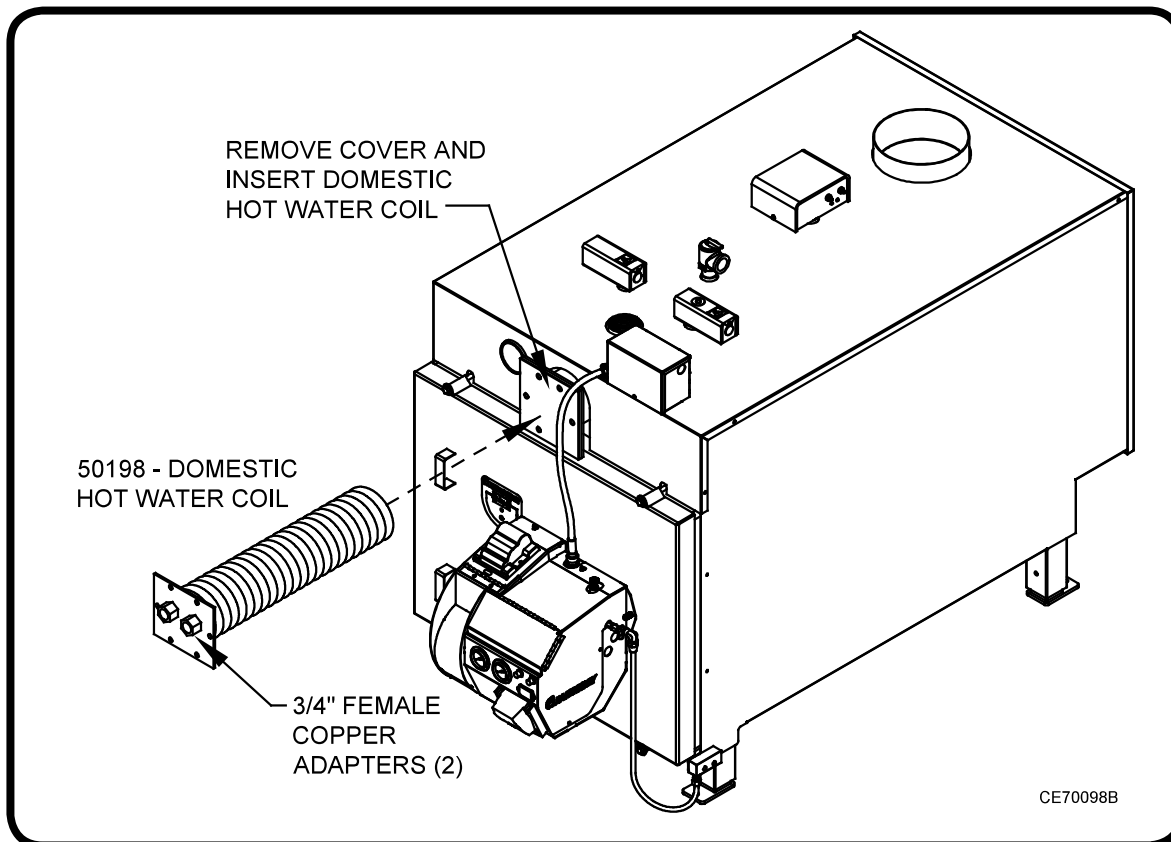

Figure A2: Domestic Hot Water Coil Location

TEN YEAR Combustion Chamber/Heat Exchanger Warranty

- From date of purchase when Warranty Card is returned within 30 days
- From date of sale from Manufacturer without returned Warranty Card

36 MONTHS Parts Warranty (From date of purchase when Warranty Card is returned within 30 days)

18 MONTHS Parts Warranty (From date of sale from Manufacturer without returned Warranty Card)

Clean Energy Heating Systems LLC, MANUFACTURER, hereby warrants the MANUFACTURER'S product to be free from defects in material and workmanship under normal use and conditions as set forth in the provisions and limitations below. The warranty extends to the original owner whose name appears on the Warranty Registration Card returned to MANUFACTURER.

**TEN YEAR COMBUSTION CHAMBER / HEAT EXCHANGER WARRANTY**

The ten year warranty on the combustion chamber / heat exchanger shall extend to the original purchaser and shall be subject to the prorated schedule of years listed in the table below:

|               |                                     |
|---------------|-------------------------------------|
| 0 to 5 years  | Repair or replace FREE of charge    |
| 6 to 10 years | Repair or replace shared cost 50/50 |

All labor and transportation costs are the responsibility of the owner. Repair or replacement shall be determined by MANUFACTURER. Photos or returned goods at owner's expense may be required for warranty determination.

**PARTS WARRANTY**

Parts are covered under warranty for 36 MONTHS from date of purchase when the Warranty Card is returned (18 MONTHS from date of sale from Manufacturer without returned Warranty Card). Owner is responsible for all labor and transportation costs associated with warranty claims.

**CONDITIONS AND LIMITATIONS:**

- A. WEAR ITEMS are not covered under warranty (*nozzles, o-rings, combustion sleeve, filters/gaskets*)
- B. The owner must complete and return the Warranty Registration Card within thirty (30) days of purchase to activate 36 MONTHS Parts Warranty Coverage.
- C. The equipment must be fired at rated capacity only with fuels listed on data label.
- D. The equipment must be installed, operated, and maintained in accordance with Federal, State, and Local regulations as well as with all MANUFACTURER'S installation and operating instructions.
- E. The equipment must not be installed in any corrosive atmosphere environment.
- F. No parts or controls may be modified, altered, or by-passed.
- G. MANUFACTURER shall not be responsible for any failure due to an Act of God.
- H. MANUFACTURER is not responsible for additions or changes made by a dealer or distributor that goes beyond the terms of this Limited Warranty.

Clean Energy Heating Systems, LLC assumes no liability for consequent damage of any kind, and by acceptance of this equipment the purchaser assumes all liability for the consequence of its use or misuse by the purchaser or others.



CLEAN ENERGY HEATING SYSTEMS, LLC  
WARRANTY CARD  
(PLEASE PRINT CLEARLY)

FIRST NAME \_\_\_\_\_ LAST NAME \_\_\_\_\_

COMPANY NAME \_\_\_\_\_

STREET \_\_\_\_\_ CITY \_\_\_\_\_ STATE \_\_\_\_\_ ZIP CODE \_\_\_\_\_

TELEPHONE \_\_\_\_\_ EMAIL \_\_\_\_\_ DATE OF PURCHASE: \_\_\_\_\_

BOILER MODEL:

CE-340

BURNER MODEL:

CE-4

BURNER SERIAL NO. \_\_\_\_\_

BOILER SERIAL NO. \_\_\_\_\_

WITHIN 30 DAYS OF PURCHASE RETURN WARRANTY CARD TO: CLEAN ENERGY HEATING SYSTEMS LLC  
PO Box 1341  
HONEY BROOK PA USA 19344



Approved Method to Dispose of Waste Oil

Sold and Serviced by:

NAME:

ADDRESS:

TELEPHONE #:

---

---

---

PLACE  
STAMP  
HERE

CLEAN ENERGY HEATING SYSTEMS LLC  
PO Box 1341  
HONEY BROOK PA USA 19344