

HEATING CENTER

BIG SAVINGS, SMALL FOOTPRINT

Our Heating Center is a cost-effective way to add the benefits of waste oil heating to just about any facility.

Consisting of an oil storage tank, funnel, pump bracket and a steel mount that can accommodate any Clean Energy furnace, the Heating Center packs clean heat and fast ROI into a small footprint. Perfect for shops, garages and facilities of all sizes, it's the easiest way to start saving money today.

INNOVATIVE FEATURES:

- » Easily mount a furnace just about anywhere
- » No need to snake oil lines long distances
- » Self-contained oil tank and stand
- » Large 250-gallon tank
- » Easy-to-use drain pan with filter screen
- » Accessible pump mount bracket
- » Weather resistant 2" breather vent
- » 4" emergency vent



INCLUDED WITH HEATING CENTER:

1. Furnace stand and legs
2. 250-gallon tank
3. Large filter drain pan
4. Pump mount bracket
5. 4" tank emergency vent
6. Vent-weather resistant breather

Includes copper tubing and fittings to connect furnace and tank

*Furnace and pump not included with heating center

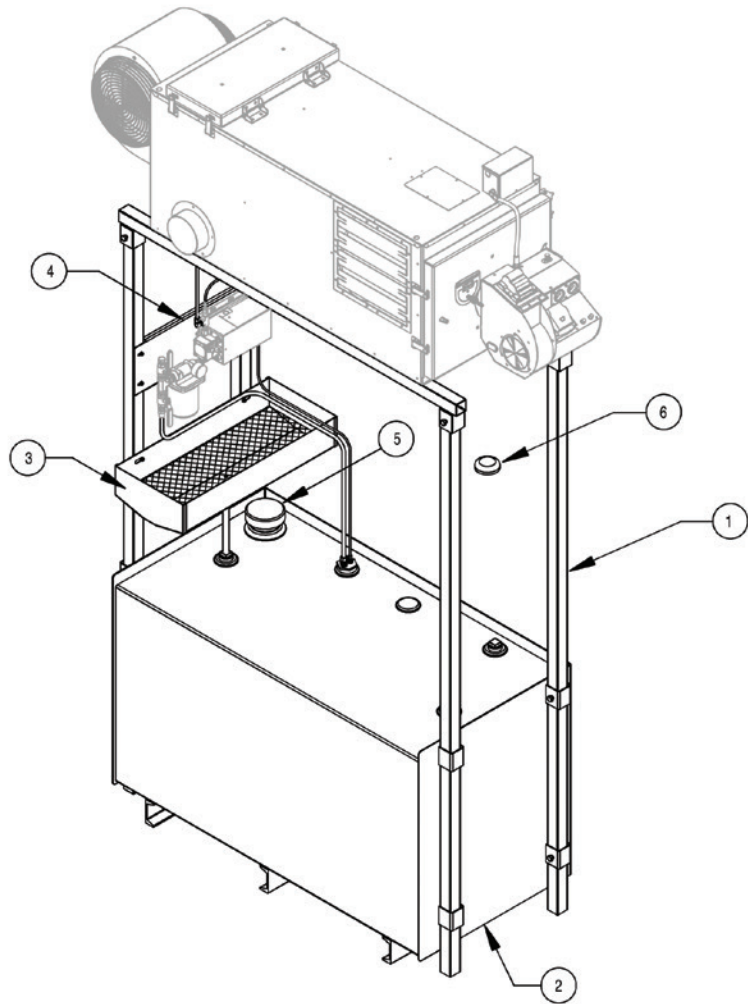

OPTIONS:

1. Low oil cut off switch
2. Air compressor
3. Air filter/regulator with drain and pressure gauge

HEATING CENTER DIMENSIONS

